

Motor and Pump Protection Relays

234-P Series

Single-Phase Pump Monitor

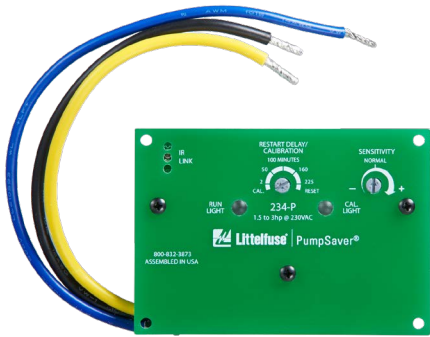

Description

The PumpSaver® Plus Model 234-P protects single-phase pumps from dry-well, dead-head, rapid-cycle, jammed impellers, and over/undervoltage conditions. Typical applications include residential waterwells, commercial waterwells, irrigation wells, golf courses, and other sprinkler systems. The Model 234-P is designed to be mounted inside a Grundfos* control box** to protect 1/3–3 hp, 2- or 3-wire, 230 V pumps. An infrared LED communicates directly with a hand-held diagnostic tool called the Informer (sold separately).

A calibration adjustment allows the 234-P to be calibrated to your specific pumping applications, reducing the possibility of false or nuisance tripping. A unique microcontroller-based voltage and current-sensing circuit constantly monitors the incoming power for fluctuations, overcurrent, and undercurrent. When an abnormality such as loss of suction is detected, the 234-P deactivates its output relay and directly disconnects the pump motor. The 234-P then begins its user-selectable restart delay (dry-well recovery) timer. When the timer counts to zero or power is removed and reapplied, the 234-P reactivates its output relay and turns the pump back on. By leaving the restart delay knob in the reset position, the 234-P will operate in manual reset mode.

The Informer displays parameters including calibration points, trip points, run time and last faults. An IR Kit-12 (12" fiber optic kit) allows the Informer to access these parameters even when the 234-P is enclosed in a control box. This is valuable for troubleshooting the pump while it is running.

NOTE: The PumpSaver® models have a sensitivity adjustment for the dry-well trip point. After calibration is done, you can adjust the sensitivity for the dry-well/dead-head trip point from 70 % - 90 % of the full load. This makes the unit even more adaptable to varying pumping applications. If you have a very low producing well, increase the sensitivity closer to the 90 % mark, or if you have a very heavy producing well, decrease the sensitivity around the 70 % mark.

* Grundfos is a trademark of its respective owner.

**The Model 234-P is not recommended for use with the Grundfos Deluxe Control Box.

Features & Benefits

FEATURES	BENEFITS
Proprietary microcontroller-based circuitry	Constant monitoring of voltage and current protects pumps from fault conditions
Onboard sensitivity adjustment	Allows user to adjust the current sensitivity for the dry-well/dead-head trip point from 70 %–90 % of the full load
Adjustable restart delay	Allows user to select well recovery time delay after a dry-well condition occurs, or to select manual reset
Built-in IR communications link	Used with the Informer, allows user to see stored faults, run time, and also troubleshoot the pump while it's running
LED indication	Provides status and diagnostics for troubleshooting

Motor and Pump Protection Relays

234-P Series

Applications

- Residential waterwells
- Commercial waterwells
- Irrigation wells
- Golf courses

Specifications

Functional Specifications

Adjustments/Settings:

Overcurrent	125 % of calibration point
Underload (dry-well)	Adjustable (70–90 % of calibrated run power)
Overvoltage	265 V ac
Undervoltage	190 V ac
Number of restarts allowed in a 60-sec. period (rapid-cycling)	4
Trip Delay Times:	
Overcurrent	5 seconds
Dry-well	4 seconds
Restart Delay Times:	
Over/undervoltage	2 seconds
All other faults (dry-well recovery timer)	Manual, 2–225 Minutes

Input Characteristics

Supply Voltage	230 V ac
Load Range	1/8–3 hp
Frequency	50/60 Hz (<i>Note: 50 Hz will increase all delay timers by 20 %</i>)

Output Characteristics

Output Contact Rating-SPST	3 hp @ 240 V ac (17 Amps max.)
-----------------------------------	--------------------------------

General Characteristics

Operating Temperature	-40 °C to 70 °C (-40 °F to 158 °F)
Maximum Input Power	5 W (max.)
Dimensions	Fitted to Grundfos* Control Box
Weight	14 oz.
Mounting Methods	Grundfos* Control Box
Standards Passed	
Electrostatic Discharge (ESD)	IEC 61000-4-2, Level 2, 4 kV contact, 6 kV air

Accessories

Informer

A hand-held diagnostic tool that uses an infrared receiver to access information which can be helpful for troubleshooting the system. Includes the Informer IR Kit-12

Informer IR Kit-12

12" infrared adapter cable attaches to the face of the unit to provide remote diagnostics without opening the panel. Included with the Informer

Motor and Pump Protection Relays

234-P Series

Ordering Information

MODEL	LINE VOLTAGE	DESCRIPTION
234-P	230 V ac	Load range: 1/4 to 3 hp

Wiring Diagram

234-P CONNECTIONS IN GRUNDFOS* CONTROL BOX

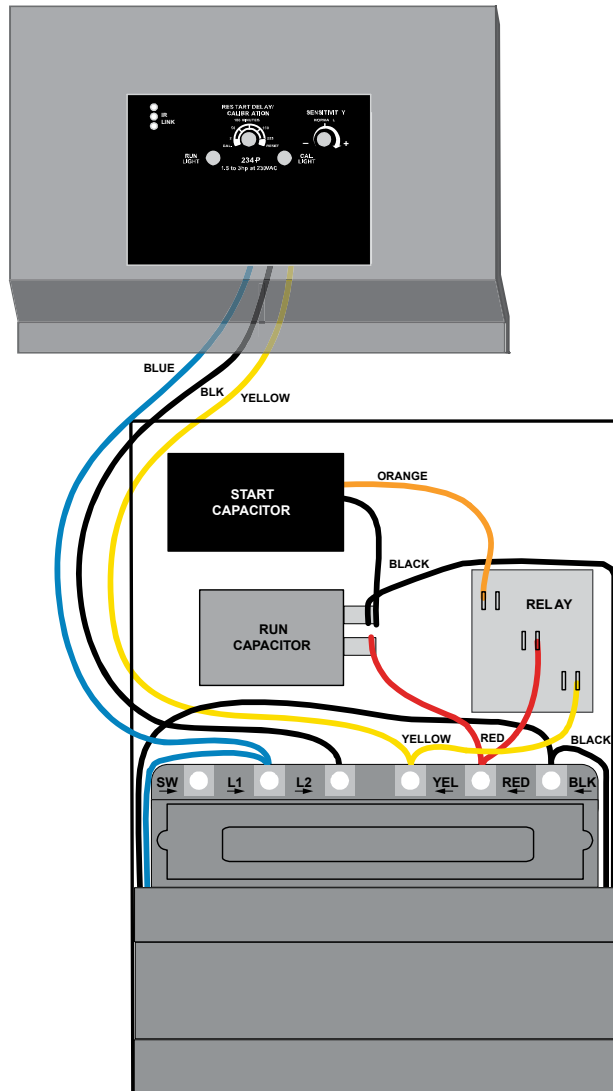

For installation instructions see the Fresh Water Pumping Catalog.

Disclaimer Notice – Information furnished is believed to be accurate and reliable. However, users should independently evaluate the suitability of and test each product selected for their own applications. Littelfuse products are not designed for, and may not be used in, all applications. Read complete Disclaimer Notice at www.littelfuse.com/product-disclaimer.