

Installation Instructions

BMZS Series Battery Mount ZCASE Fuse Holder with Studs

Part Numbers: FHZ00861, FHZ00862, and FHZ00863

Description

The ZCASE® BMZS Series 80V Battery-Mounted Fuse Holder with Studs features a forged base with a battery post clamp and pre-installed M10 insulated studs. This high-current fuse holder allows you to connect M10 ZCASE® fuses (sold separately) to a stud-type power source for highamp circuit protection and terminal connections for positive circuits.

Made with forged brass, the battery terminal fuse holder is designed to withstand operation for 10 years and 10,000 hours for heavy-duty, high-current applications in crowded spaces.

The ZCASE® BMZS Series is available as a single-fuse holder as well as a multi-fuse holder (2- or 3- position). The 2-position fuse holder has the option for the included bolt-on battery post adapter to be installed in either of the outer positions.

Installation Instructions

Following the below sequence to install the Fuse Holder:

1. Place the tail end of the cover onto the positive battery post, with the inside of the cover facing upwards.
2. Tighten the battery post included with the BMZF 2-Position into either of the outer mating holes of the base, torquing to $16\pm 1\text{N}\cdot\text{m}$. *Step 1 applicable only to 2-Position design
3. Place insulated stud on base.
4. Place the ZCASE fuse, then the M10 ring terminal of the battery cable, onto the base. Align the holes and fit the required insulated stud (PN: 908-082) though to the base. Tighten the nut to $16\pm 2\text{N}\cdot\text{m}$. Be sure the ring terminal dimensions match the FIGURE 1 Requirements. If more than one ring terminal size is used, the thickness of each must be within 2mm of each other.
5. Place the battery clamp end of the base assembly onto the positive battery post, on top of the cover. Secure the base assembly to the post by tightening the M8 shoulder hex nut to $12\pm 1\text{N}\cdot\text{m}$. The clamp bolt and nut can be installed pointing in either direction.
6. Wrap the cover over the top of the base assembly and secure the feature on the inside of the cover over the insulated bolt head(s). The ring terminal and the cable from each fuse will extend out of one of the surrounding cover flaps.

Figure 1

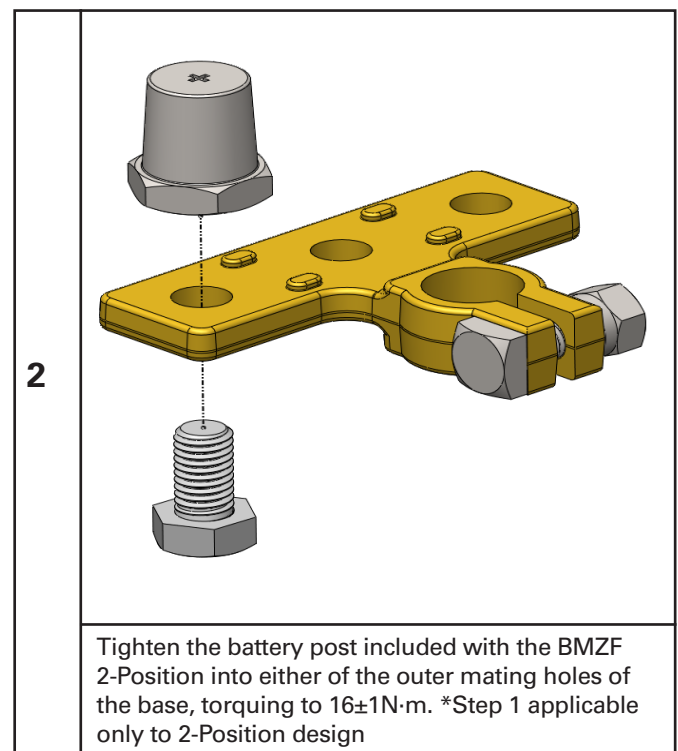
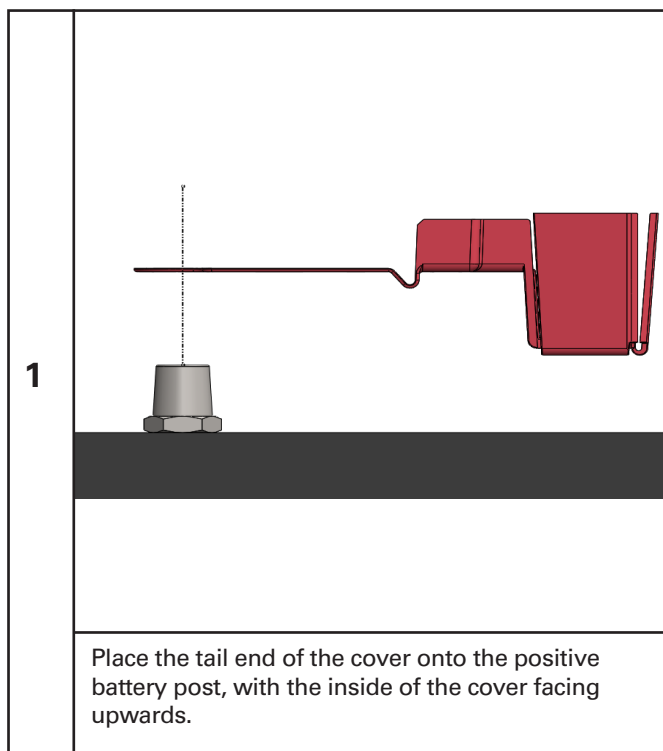
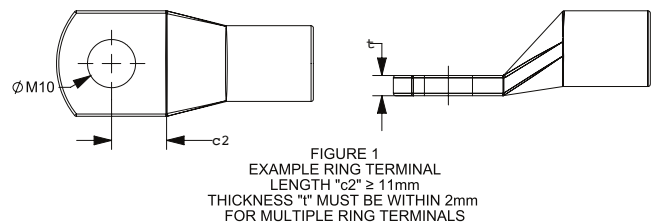

Installation Instructions

BMZS Series Battery Mount ZCASE Fuse Holder with Studs

Part Numbers: FHZ00861, FHZ00862, and FHZ00863

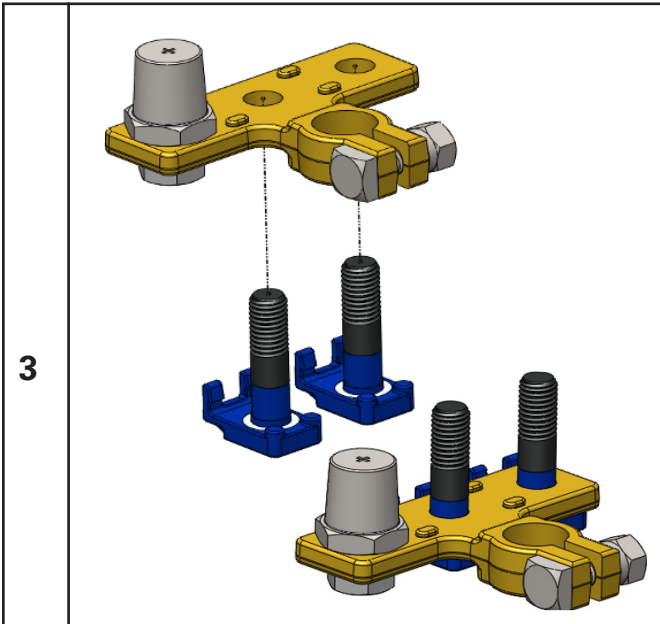

Place insulated stud on base.

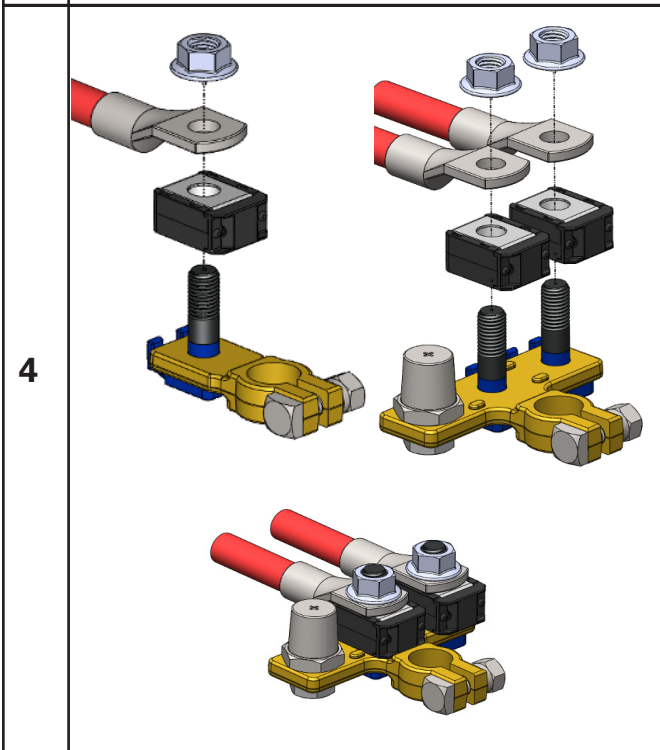

Place the ZCASE fuse, then the M10 ring terminal of the battery cable, onto the base. Align the holes and fit the required insulated stud (PN: 908-082) through to the base. Tighten the nut to 16 ± 2 N·m. Be sure the ring terminal dimensions match the FIGURE 1 Requirements. If more than one ring terminal size is used, the thickness of each must be within 2mm of each other.

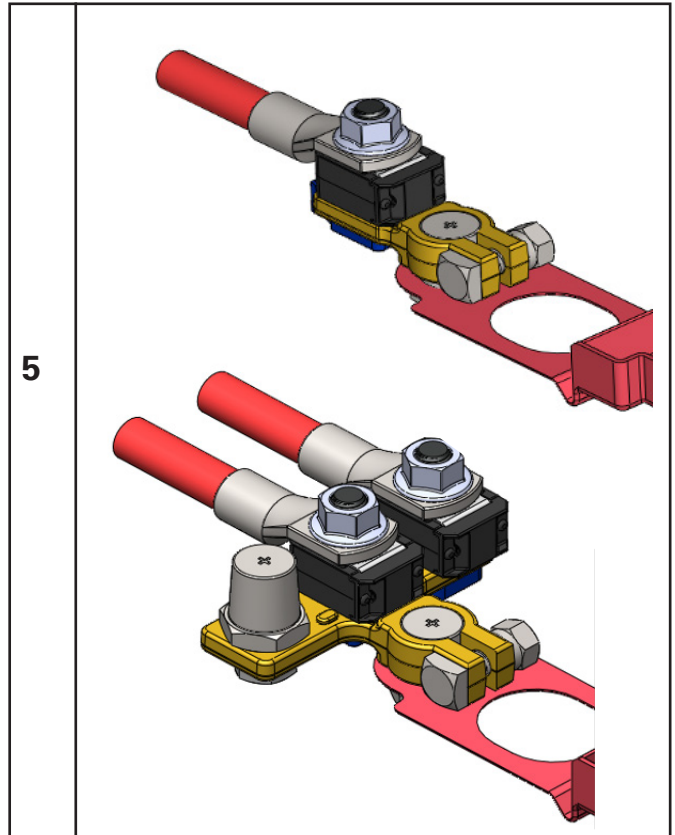

Place the battery clamp end of the base assembly onto the positive battery post, on top of the cover. Secure the base assembly to the post by tightening the M8 shoulder hex nut to 12 ± 1 N·m. The clamp bolt and nut can be installed pointing in either direction.

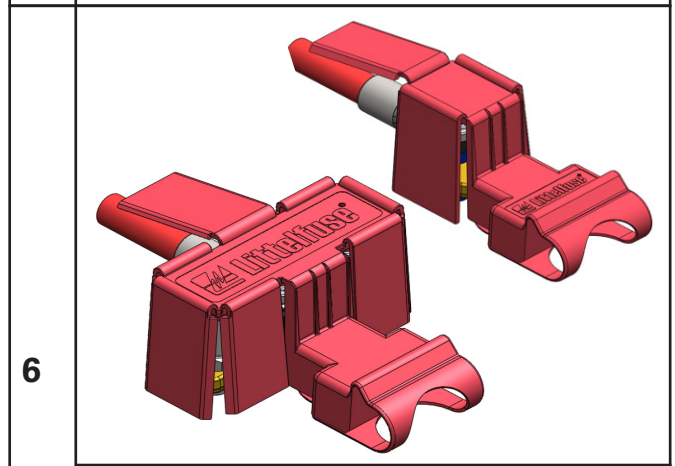

Wrap the cover over the top of the base assembly and secure the feature on the inside of the cover over the insulated bolt head(s). The ring terminal and the cable from each fuse will extend out of one of the surrounding cover flaps.