

REVISIONS				
ZONE	REV.	DESCRIPTION	DATE	APPROVED
	A	PCO-500000301372 INITIAL RELEASE	AUG./22/2025	D. ZHANG

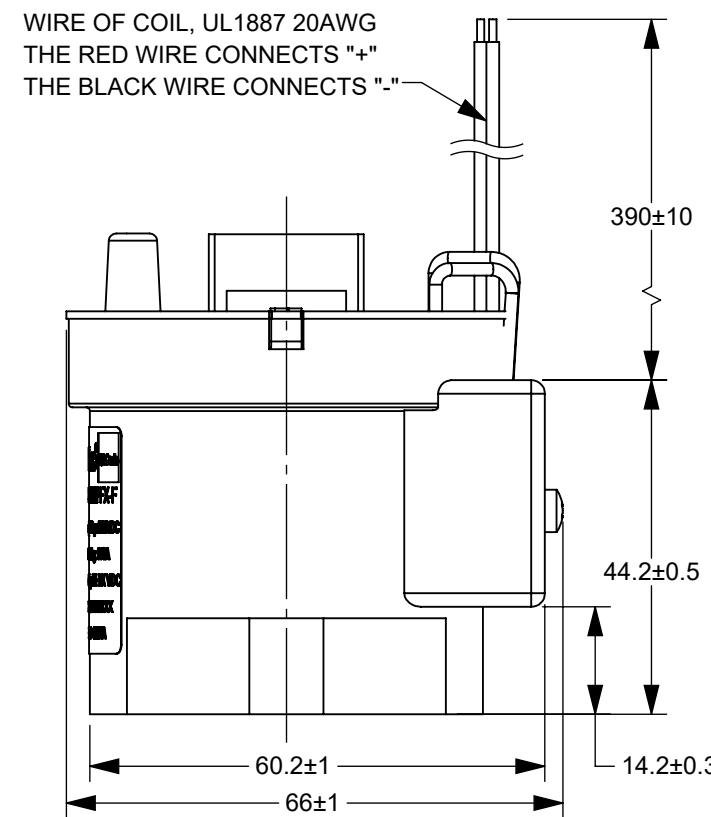

DCNHE150PF SERIES SCHEMATIC CIRCUIT DIAGRAM

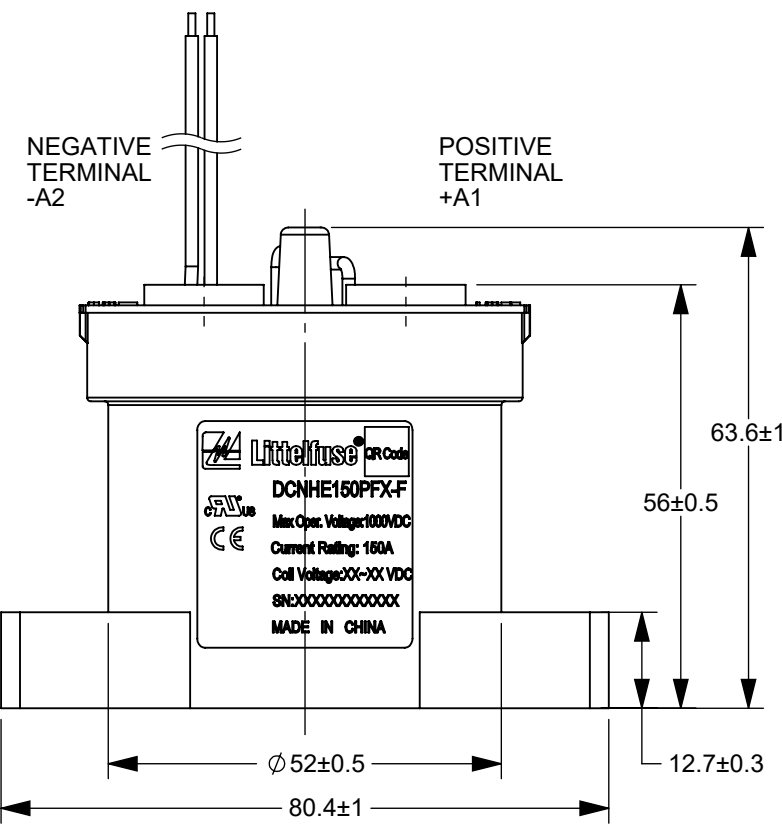
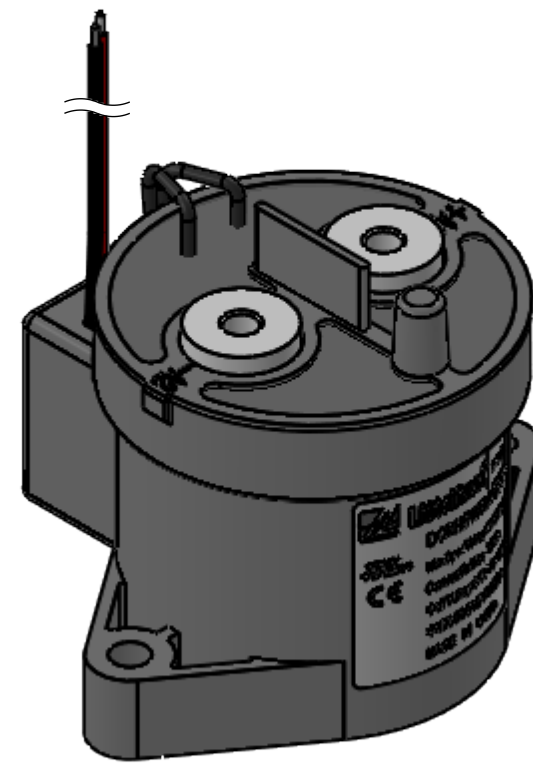
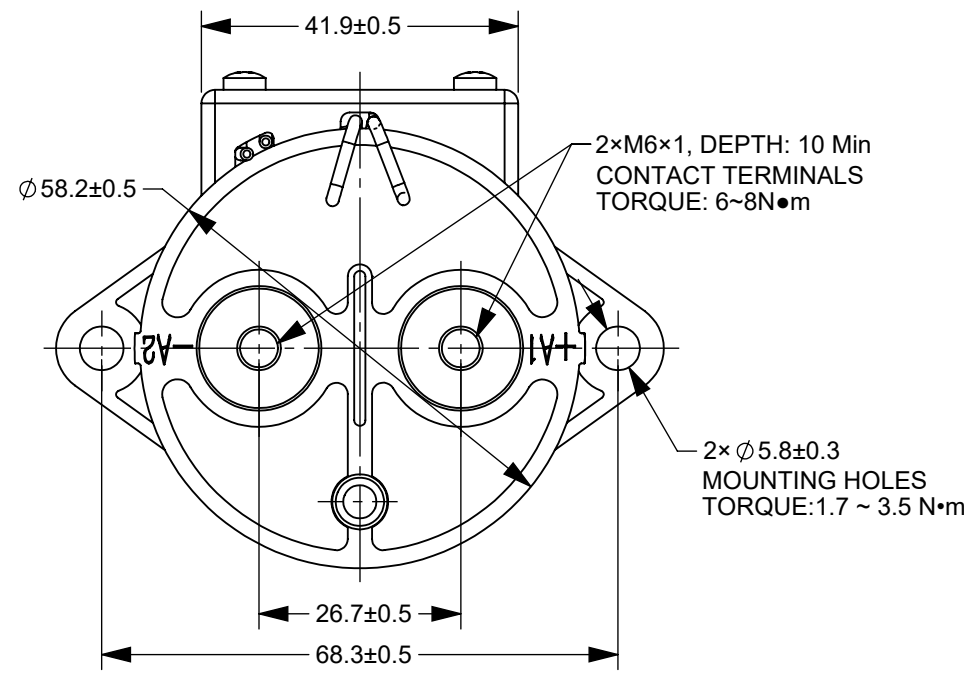
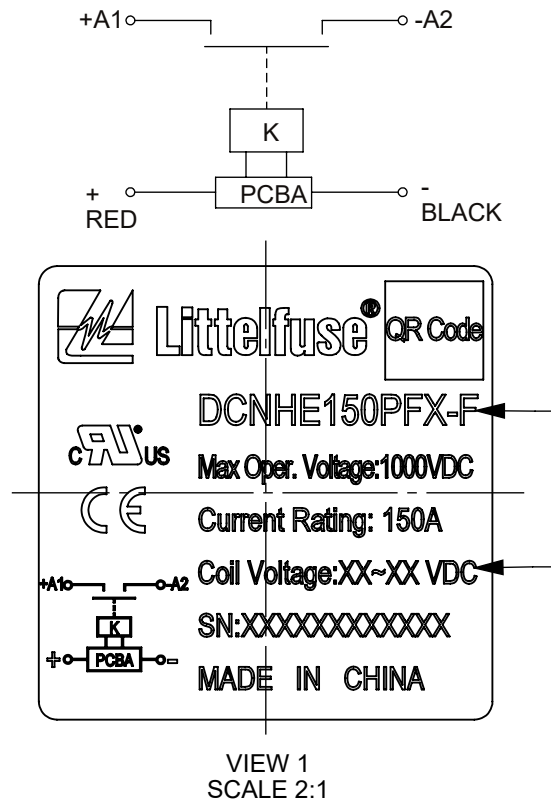

VIEW 1 SCALE 2:1

TABLE 1

PN		DCNHE150PFA-F
MAX. OPERATING VOLTAGE		1,000V DC
RATED CONTACT CURRENT		150A
COIL VOLTAGE		12~36V DC
OPERATING VOLTAGE IN COLD STATE@25°C	PICK-UP	8~9V DC
	RELEASE	5~7V DC
STARTING CURRENT@25°C		2.4A@12V DC; 2A@24V DC
HOLDING POWER@25°C		APPROX. 2.5W
VOLTAGE DROP		≤80mV@150A
Max. BREAKING CURRENT		2,000A@320V DC, 1CYCLE
INSULATION RESISTANCE@500V DC (INITIAL)		≥100MΩ
DIELECTRIC STRENGTH (LEAKAGE CURRENT≤1 mA)	BETWEEN CONTACTS	4,000V AC, 1 MINUTE
	BETWEEN COIL AND CONTACTS	2,200V AC, 1 MINUTE
ELECTRIC LIFE (RESISTIVE LOAD)		6,000 CYCLES (150A@450V DC) 2,000 CYCLES (150A@750V DC) 1,000 CYCLES (100A@1000V DC)
MECHANICAL LIFE (NO LOAD, CYCLES)		300,000

TABLE 2

NO.	PN	"A"	"B"	CERTIFICATIONS	REMARK
1	DCNHE150PFA-F	DCNHE150PFA-F	Coil Voltage:12~36VDC	UL,CE	NAMEPLATE:VIEW 1
2					

NOTES:

- ALL DIMENSIONS ARE REFERENCE ONLY.
- CONTACTOR PARAMETERS ARE SHOWN IN TABLE 1, CERTIFICATIONS INFORMATION ARE SHOWN IN TABLE 2.
- SEE TABLE 2 FOR NAME PLATE AND PNs.
- PRODUCT TYPE: SPST-NO, POLAR CONTACTOR.
- MATERIALS AND FINISH:
 - HOUSING: THERMOPLASTIC PLASTICS.
 - CONTACTS: SILVER-PLATED COPPER.
 - CONTACT STUDS: SILVER-PLATED COPPER.
- WEIGHT: ABOUT 450GRAMS.
- RoHS COMPLIANT.
- THE COIL AND CONTACTS OF THE CONTACTOR ARE POLAR, SO THE CONNECTION OF THE COIL AND CONTACTS SHOULD BE OPERATED ACCORDING TO THE SCHEMATIC CIRCUIT DIAGRAM.

DIMENSIONS ARE SHOWN IN MILLIMETERS. DIMENSIONS AND TOLERANCES ARE DEFINED ACCORDING TO ANSI/ASME Y14.5-1994.

●	FTI/ FUNCTION CRITICAL CHARACTERISTICS
<S>	SAFETY/ COMPLIANCE CRITICAL CHARACTERISTICS SYMBOL
CPK	DENOTES CPK DIMENSIONS MINIMUM CPK VALUE
(ST)	DENOTES A CHARACTERISTIC THAT PROVIDES AN INDICATION OF PROCESS PERFORMANCE. PROCEDURE FOR MEASUREMENT AND TRACKING TO BE DEFINED IN LITTELFUSE INSPECTION INSTRUCTIONS
CP	DENOTES CP DIMENSIONS. -MINIMUM CP VALUE MUST BE WITHIN THE DIMENSIONAL LIMITATIONS SHOWN ON DRAWING AND INITIALLY LOCATED TO ALLOW FOR MAXIMUM TOOL LIFE

NAME	DATE	<p>Expertise Applied Answers Delivered</p> <p>TITLE DCNHE POLAR CONTACTOR</p>
DRAWN	JY. SHI MAY./15/2025	
CHECKED	V. ZHANG MAY./16/2025	
FORM NO.	CVP-PE40-0005 REV B	
THIRD ANGLE PROJECTION		SIZE C DWG. NO. OL-DCNHE150PFX-F, CHT REV. A DO NOT SCALE DRAWING SCALE 1:1 SHEET 1 OF 1