

REVISIONS				
ZONE	REV.	DESCRIPTION	DATE	APPROVED
	A	GCF#524592 INITIAL RELEASE	DEC./03/2021	D. ZHANG

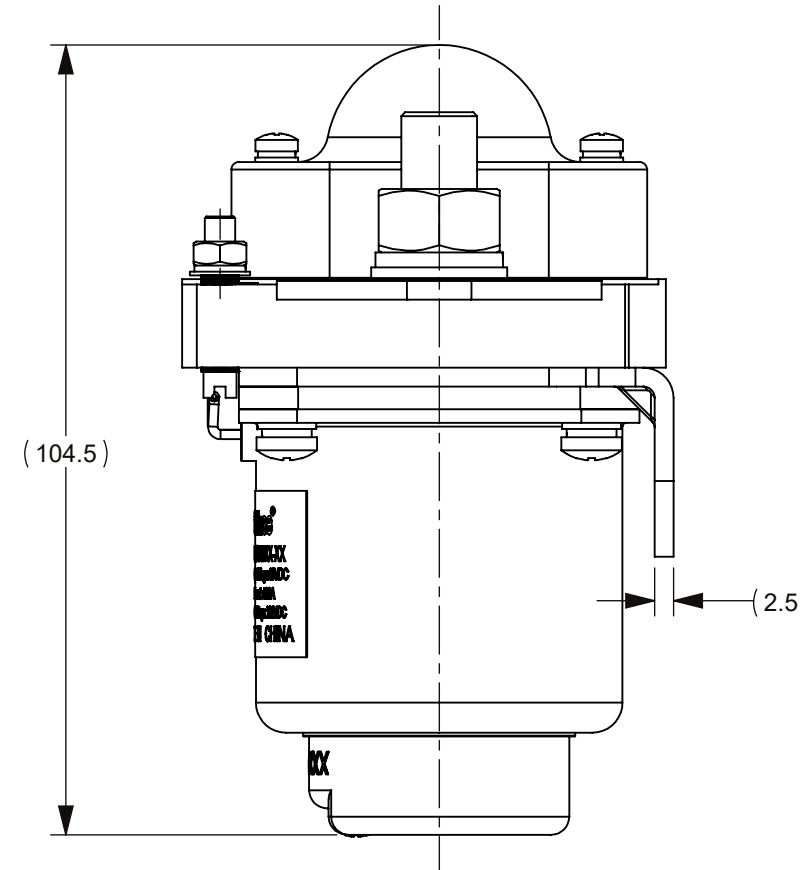

CIRCUIT SCHEMATIC DIAGRAM

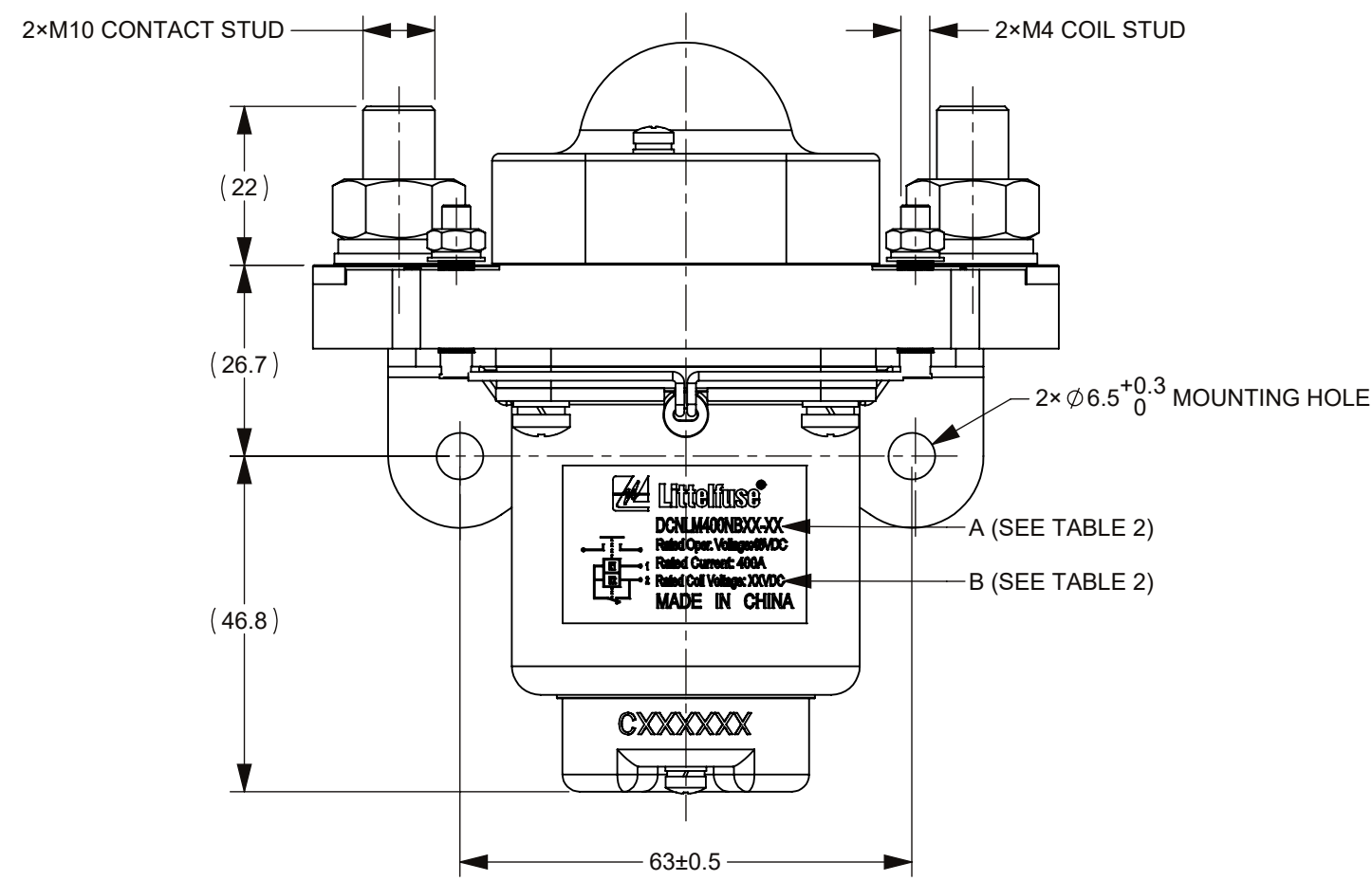
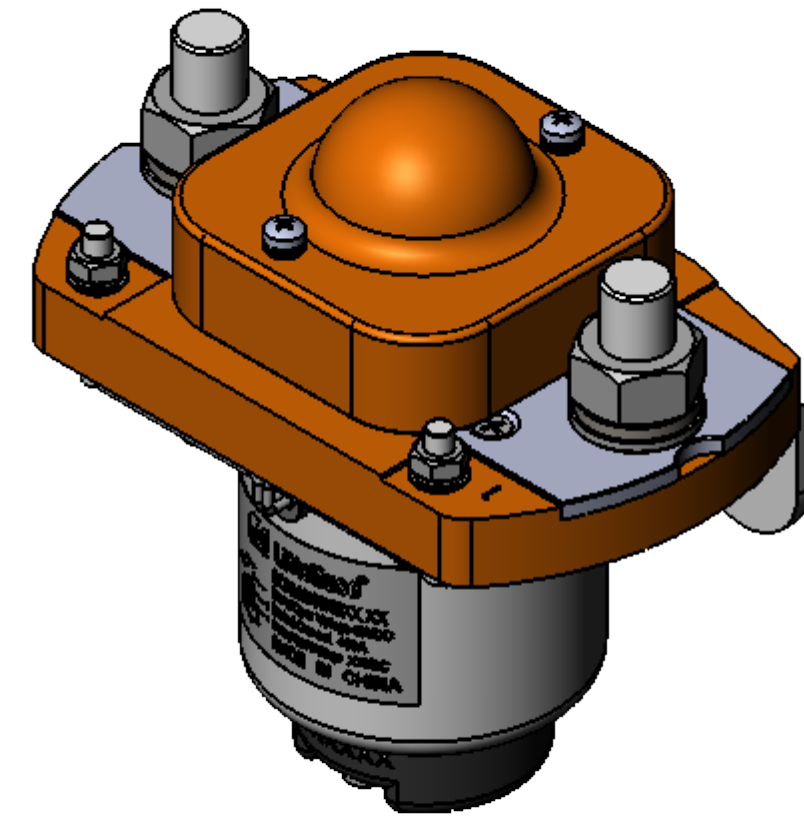
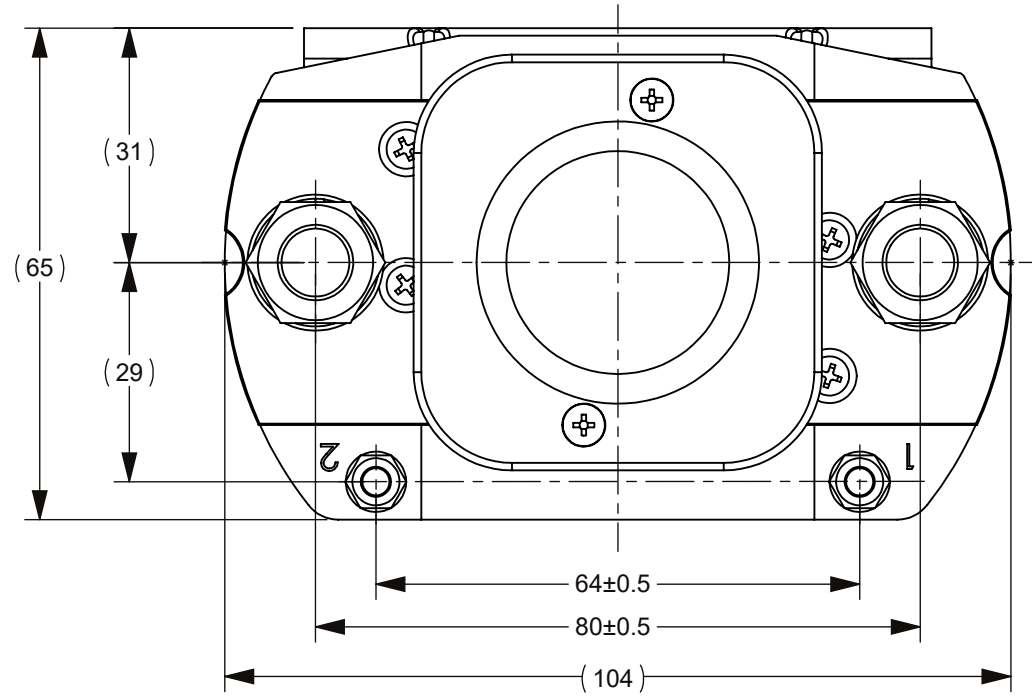
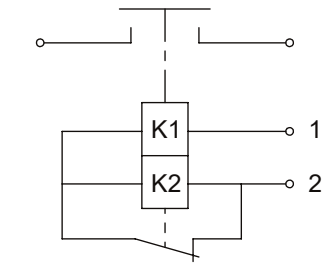

TABLE 1: TECHNICAL PARAMETERS

ITEM	PARAMETER		
	DCNLM400NB12	DCNLM400NB24-01	DCNLM400NB48-01
RATED COIL VOLTAGE	12V DC	24V DC	48V DC
HOLD POWER	START POWER	MAX 80W	MAX 175W
	MAINTAIN POWER	MAX 10W	MAX 11.5W
OPERATING VOLTAGE IN COLD STATE AT (20±5)°C	PICKUP	MAX 8.4V DC	MAX 16.8V DC
	RELEASE	MIN 1V DC	MIN 2V DC
OPERATE TIME	MAX 50ms		
RELEASE TIME	MAX 20ms		
BOUNCE TIME	MAX 7ms		
RATED CONTACT VOLTAGE	48V DC		
MAXIMUM CONTACT VOLTAGE	60V DC		
RATED CONTACT CURRENT	400A		
CONTACT VOLTAGE DROP	≤50mV@100 A		
LIMIT BREAKING ABILITY	4Ie/5ms,1CYCLES		
DIELECTRIC STRENGTH	1000V AC, 50Hz,1min., LEAKAGE CURRENT ≤1 mA		
INSULATION RESISTANCE	≥50MΩ@500VDC		
ELECTRIC LIFE	6000 CYCLES		
MECHANICAL LIFE	100,000 CYCLES		
WORKING DUTY	CONTINUOUS		

NOTES:

- ALL SIZES ARE FOR REFERENCE ONLY.
- MATERIALS AND FINISHING:
 - BASE: THERMOSETTING PLASTIC, UL94V-0.
 - CONTACTS: SILVER ALLOY.
 - COIL STUD: COPPER ALLY, SILVER PLATED.
- PRODUCT TECHNICAL PARAMETERS: SEE TABLE 1.
- PRODUCT AND NAMEPLATE(THE CHARACTER CONTENT AT "A" AND "B")CONFIGURATION SEE TABLE 2.
- CONTACT ARRANGEMENT: SPST-NO.
- CONNECTION STUD: M10 STUD, RECOMMENDED TORQUE 15 N·m ~ 18 N·m; M4 STUD, RECOMMENDED TORQUE 1.7 N·m ~ 2.5 N·m.
- MOUNTING: M6 BOLT, RECOMMENDED TORQUE 6 N·m ~ 8 N·m.

TABLE 2

PRODUCT PN	"A"	"B"
DCNLM400NB12	DCNLM400NB12	Rated Coil Voltage: 12VDC
DCNLM400NB24-01	DCNLM400NB24-01	Rated Coil Voltage: 24VDC
DCNLM400NB48-01	DCNLM400NB48-01	Rated Coil Voltage: 48VDC

DIMENSIONS ARE SHOWN IN MILLIMETERS. DIMENSIONS AND TOLERANCES ARE DEFINED ACCORDING TO ANSI/ASME Y14.5-1994.

●	FTI/ FUNCTION CRITICAL CHARACTERISTICS
<S>	SAFETY/ COMPLIANCE CRITICAL CHARACTERISTICS SYMBOL
CPK	DENOTES CPK DIMENSIONS MINIMUM CPK VALUE
(ST)	DENOTES A CHARACTERISTIC THAT PROVIDES AN INDICATION OF PROCESS PERFORMANCE PROCEDURE FOR MEASUREMENT AND TRACKING TO BE DEFINED IN LITTELFUSE INSPECTION INSTRUCTIONS
CP	DENOTES CP DIMENSIONS. -MINIMUM CP VALUE MUST BE WITHIN THE DIMENSIONAL LIMITATIONS SHOWN ON DRAWING AND INITIALLY LOCATED TO ALLOW FOR MAXIMUM TOOL LIFE

NAME	DATE	<p>Expertise Applied Answers Delivered</p>
DRAWN MJ. DAI	SEP./20/2021	
CHECKED J. LI	SEP./25/2021	TITLE
		DCNL 400A 48V CONTACTOR
FORM NO. CVP-PE40-0005 REV B		SIZE
THIRD ANGLE PROJECTION		C
		DWG. NO.
		OUTLINE
DO NOT SCALE DRAWING	SCALE 1:1	REV. A
		SHEET 1 OF 1