

SHORT CIRCUIT CURRENT RATINGS

How to Determine and Increase Short Circuit Current Ratings for Industrial Control Panels



WHITE PAPER



Expertise Applied | Answers Delivered

Introduction

A short-circuit current rating (SCCR)¹ is the maximum current a device or system can safely withstand for a specified time (such as 0.05 seconds), or until a specified fuse or circuit breaker opens and clears the circuit. SCCR is usually expressed in kiloamperes (kA).

SCCR labeling requirements create a safe installation and help manufacturers, owners and managers meet OSHA regulations and NFPA codes and standards.

Both the NEC and OSHA forbid equipment from being located near any point where the available short-circuit current is more than what the equipment can withstand.

Available fault currents are increasing in industrial facilities due to a continuously increasing demand for electric power. When available fault currents at the equipment exceed the panel's SCCR, there can be catastrophic results.

Current-limiting fuses can optimize a panel to give it a strong competitive advantage over molded case circuit breakers (MCCB) so long as SCCR is considered in its design. Most MCCBs do not provide adequate SCCRs.

The most traditional way to increase a panel's low SCCR that is caused from an MCCB is to replace the MCCB with current-limiting fuses. But after making this improvement to the panel, how can you increase the panel's SCCR even further?

Why Must Industrial Control Panels Be Marked with Their SCCR?

NEC Article 409.110 requires industrial control panels (ICP) to be visibly marked with the panel's overall SCCR. NEC Article 409 requires an analysis of panels and facilities to be conducted for potential electrical hazards. The marked SCCR must be based on either the SCCR of a listed and labeled assembly or on an SCCR that was established by an approved method. Overcurrent protective devices must also be marked with an interrupting rating or an ampere interrupting capacity.

A common misconception among equipment manufacturers is that the ampere interrupting capacity or the interrupting rating (IR) of the main circuit protection device is the same as the industrial control panel's (ICP) SCCR. This can confuse personnel about where the panel may be safely used. For example, before the introduction of NEC Article 409 in 2005,

if a panel had a main feeder circuit protective device with an interrupting rating of 22 kA, then the manufacturer of an unapproved panel would also label their panel with an SCCR of 22 kA.

However, each power component within the panel has a different SCCR or IR, many of which are likely to have a rating of 5 kA or less. Therefore, if a 22-kA fault occurs, even if the main circuit protective device can safely interrupt the fault, one or more of the power components within the panel can still potentially catch on fire or violently explode.

The NEC specifically requires SCCR markings for:

- Services (Article 230)
- Industrial Control Panels (Article 409)
- Motors, Motor Circuits, and Controllers (Article 430)
- Air-Conditioning and Refrigerating Equipment (Article 440)
- Elevators, Dumbwaiters, Escalators, Moving Walks, Platform Lifts, and Stairway Chairlifts (Article 620)
- Industrial Machinery (Article 670)
- Emergency Systems (Article 700)
- Legally Required Standby Systems (Article 701)
- Optional Standby Systems (Article 702)
- Critical Operations Power Systems (Article 708)

These markings allow installers and inspectors to compare fault current studies at the facility where the panels are intended to be installed to the SCCR of the control panel to minimize potential hazards in industrial or commercial facilities.

For safety and reliability, it is essential to compare accurate SCCR markings on equipment with the available fault currents on a regular basis.

¹ Short-circuit current ratings were known as "withstand ratings" before the NEC first defined it in the 1999 edition.

What is a Current-Limiting Overcurrent Protective Device?

Current-limiting overcurrent protective devices, as defined by Article 240.2 of the NEC, reduce the current flowing in a faulted circuit to a magnitude that is substantially less than what would otherwise be obtained if the device were replaced with a solid conductor with a comparable impedance. When operating in their current-limiting range, these devices can clear a short circuit current in less than 8.3 milliseconds, which is less than one half of an electrical ac cycle (see **Figure 1**).

Current-limiting overcurrent protective devices must interrupt currents in their current-limiting range to be effective.

How Does Current Limitation Increase SCCRs?

Current limitation increases SCCRs because it reduces the destructive thermal energy. **Figure 1** shows the maximum instantaneous peak current (I_{peak}) during the first half cycle after the initiation of a fault. The gray area represents what the I_{peak} will be without the use of current-limiting fuses, while the green area depicts the I_{peak} when current-limiting fuses are used.

Depending on the power factor and when the fault occurs, the maximum possible I_{peak} without current limitation can be as high as 2.3 times the available rms fault current when the fault occurs. However, when current-limiting fuses are used, the maximum I_{peak} is only a small fraction of what the potential flow would otherwise be. The area under the curve represents the I^2t let-through energy of the fuse. The lower the I^2t , the lower the potentially destructive thermal energy will be that passes through the circuit when it is interrupted.

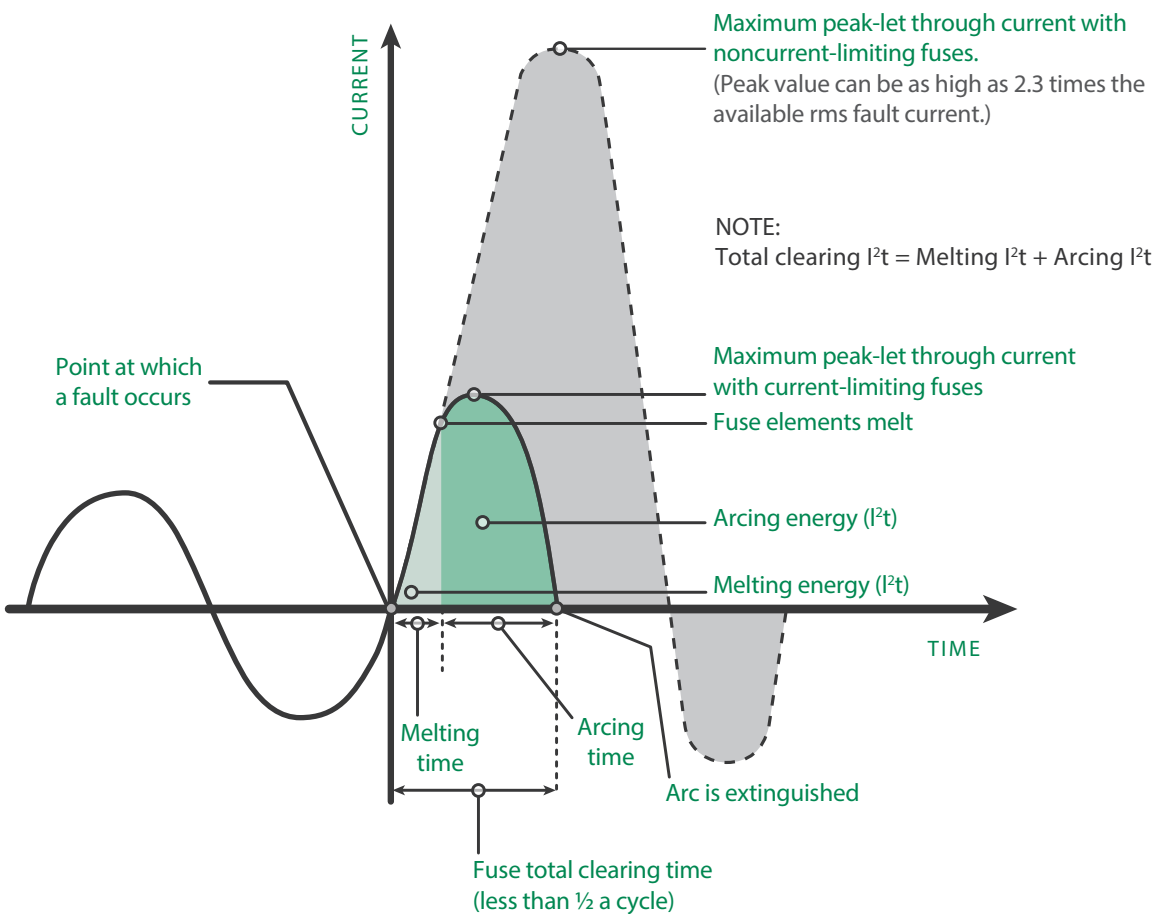

Figure 1. Maximum instantaneous peak current during first 1/2 cycle of a fault with current-limiting fuses versus noncurrent-limiting fuses.

Interrupting Ratings for Overcurrent Protective Devices

Although fuses and circuit breakers are tested using different methods, a fuse's interrupting rating (as well as the AIC of a circuit breaker) is considered to be the same as its SCCR.

NEC Article 110.9 says that "equipment intended to interrupt current at fault levels shall have an interrupting rating at nominal circuit voltage at least equal to the current that is available at the line terminals of the equipment."

NEC Article 110.10 specifically requires the coordination of overcurrent protective devices and the components that they are designed to protect. This prevents extensive damage to any component or circuit in the event of a short circuit fault.

Fuses and circuit breakers that are Listed or Recognized by an NRTL are tested in a laboratory to verify that they can safely interrupt certain fault currents. To obtain certifications, a fuse must open safely and not damage itself or anything around it. It also may not vent hot gases, which can ignite flammable surroundings.

Circuit breakers must also open safely under controlled conditions and not ignite nearby objects. Circuit breakers, however, can vent high-temperature gases and can be a source of ignition in hazardous areas.

Some circuit breakers and supplementary protectors are tested and approved to be able to safely interrupt a high-level short circuit current only one time. After the first interruption, these circuit breakers may not be operable and cannot be approved to be used again.

Rms versus I_{peak}

The SCCR of components in panels is expressed as *rms* kA. Root mean square (rms) current is an expression of effective current over a time period.

Conversely, if the I_{peak} of a current-limiting fuse is 23 kA, then the equivalent or apparent rms value is 0.435 times the I_{peak} , or 10 kA. When properly applied, current-limiting fuses will limit the I_{peak} and apparent rms short circuit current to a level that the rest of the panel can safely handle. This action is sometimes used to determine the SCCR of ICPs.

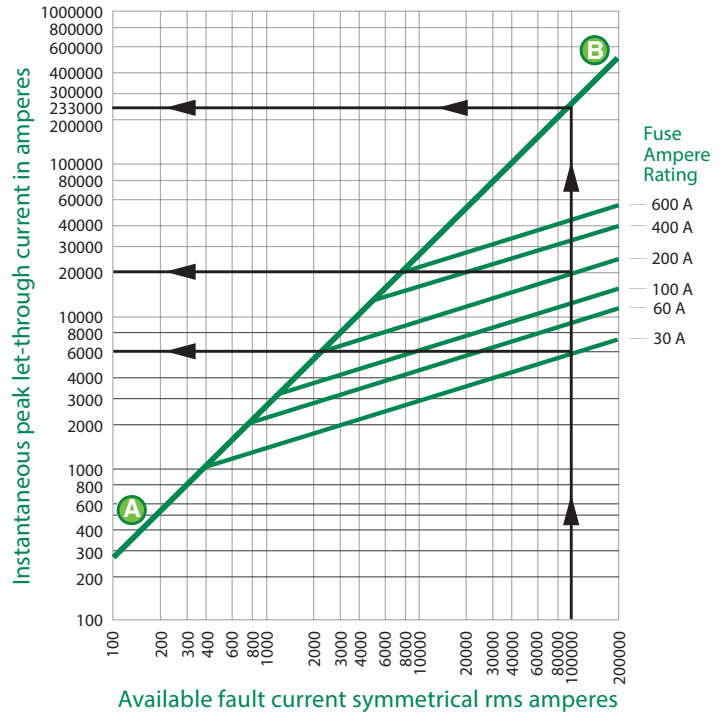

Figure 2. Relationship between available rms fault current and maximum instantaneous peak during a short circuit.

Current Limitation and Peak Let-through Charts

Current-limiting fuses operating in their current-limiting range will limit the maximum instantaneous peak current (I_{peak}) to a value that is substantially less than the peak current that could flow if the fuse were not in the circuit.

Figure 2 shows the relationship between the available symmetrical rms fault current and the maximum possible I_{peak} if a short circuit occurs. **Figure 2(A-B)** is the maximum possible I_{peak} under worst-case conditions (15 % power factor, asymmetrical), or 2.3 times the available symmetrical rms fault current. The other lines in **Figure 2** illustrate how ampere ratings of standard current-limiting fuses affect the peak let-through.

For example, if the available symmetrical rms fault current at the line side terminals of a panel is 100,000 A, then the maximum possible I_{peak} without a current limitation is 233,000 amperes (see **Figure 2(A-B)**). However, when a 200-ampere current-limiting fuse is used, then the maximum I_{peak} is limited to about 20,000 amperes. If a 30-ampere fuse is used, then the maximum I_{peak} is limited to about 6,000 amperes.

How to Determine and Increase Short-Circuit Current Ratings for Industrial Control Panels

Peak let-through charts estimate the equivalent or apparent symmetrical rms fault current that a system can withstand (see **Figure 3**). For example, if the available symmetrical rms fault current at the line side terminals of a 600-ampere current-limiting fuse is 100,000 amperes (see **Figure 3(a)**), then the fuse will clear within the first ½ cycle and limit the maximum I_{peak} to no more than 45,000 amperes (see **Figure 3(b)**). An I_{peak} of 45,000 amperes (see **Figure 3(b)**) has the same maximum I_{peak} (see **Figure 3(c)**) that 18,000 amperes of rms current can generate (see **Figure 3(d)**).

In other words, if the actual available fault current is 100,000 amperes, then a 600-ampere current-limiting fuse will limit the I_{peak} to an equivalent available rms current of 18 kA.

Peak Let-Through Chart Example

Before submitting it to UL or another NRTL to have it officially tested, it is a good idea to estimate the maximum prospective rms fault current or SCCR that the ICP can safely handle.

Consider this example of a standard ICP that has:

- an available rms fault current of 60,000 A at 480 V ac;
- a fusible disconnect switch in the main feeder circuit with three [Littelfuse JTD_ID UL Class J fuses](#); and
- a lowest-rated SCCR component of 5 kA.

If a prospective 60 kA symmetrical rms fault occurs, the 60-ampere JTD_ID fuses will limit the apparent rms symmetrical let-through current to 5 kA or less.

We know this because of the peak let through charts. Based on the peak let-through curve (see **Figure 4**), the prospective available symmetrical rms fault current is 60,000 A. The 60-ampere Class J fuses limit the maximum I_{peak} to about 7,400 A. Moving horizontally over to the maximum I_{peak} line and downward back to the prospective available rms symmetrical fault line, the apparent rms symmetrical fault current is about 3,200 A.

A 60-ampere Class J fuse can safely protect any component in series with it that has an SCCR of more than 3,200 amperes if a prospective rms symmetrical fault current of 60,000 amperes occurs. This is because of the fuse's maximum equivalent rms fault current available to the other components in the panel.

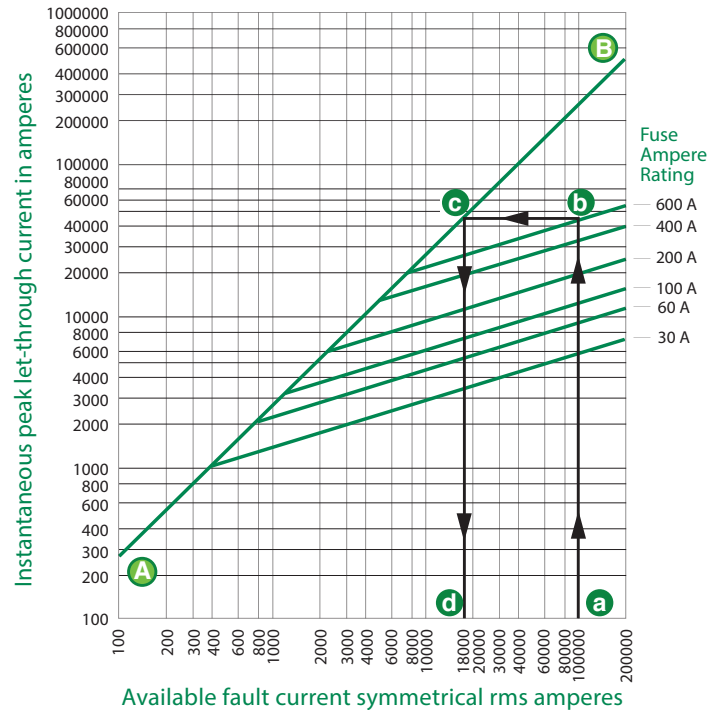

Figure 3. Peak let-through chart for estimating a system's maximum withstandable rms fault current.

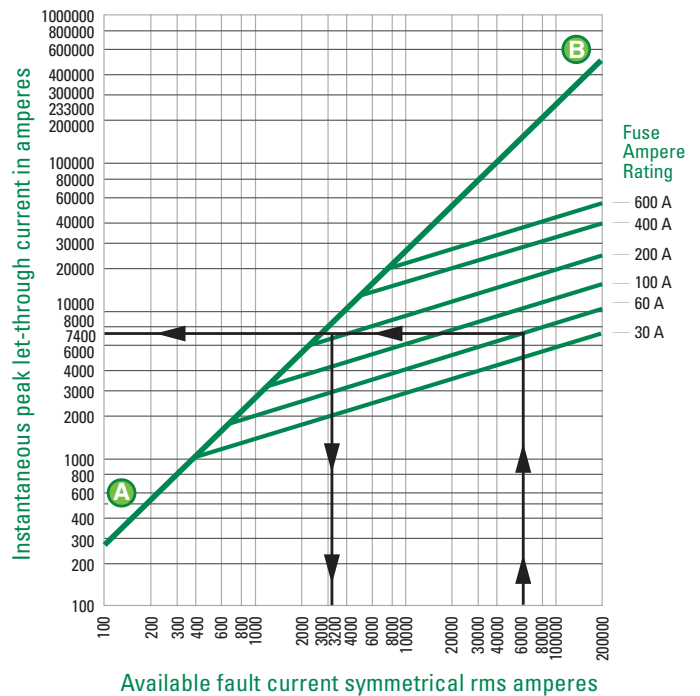

Figure 4. Peak let-through curve for Littelfuse JTD_ID Class J fuses.

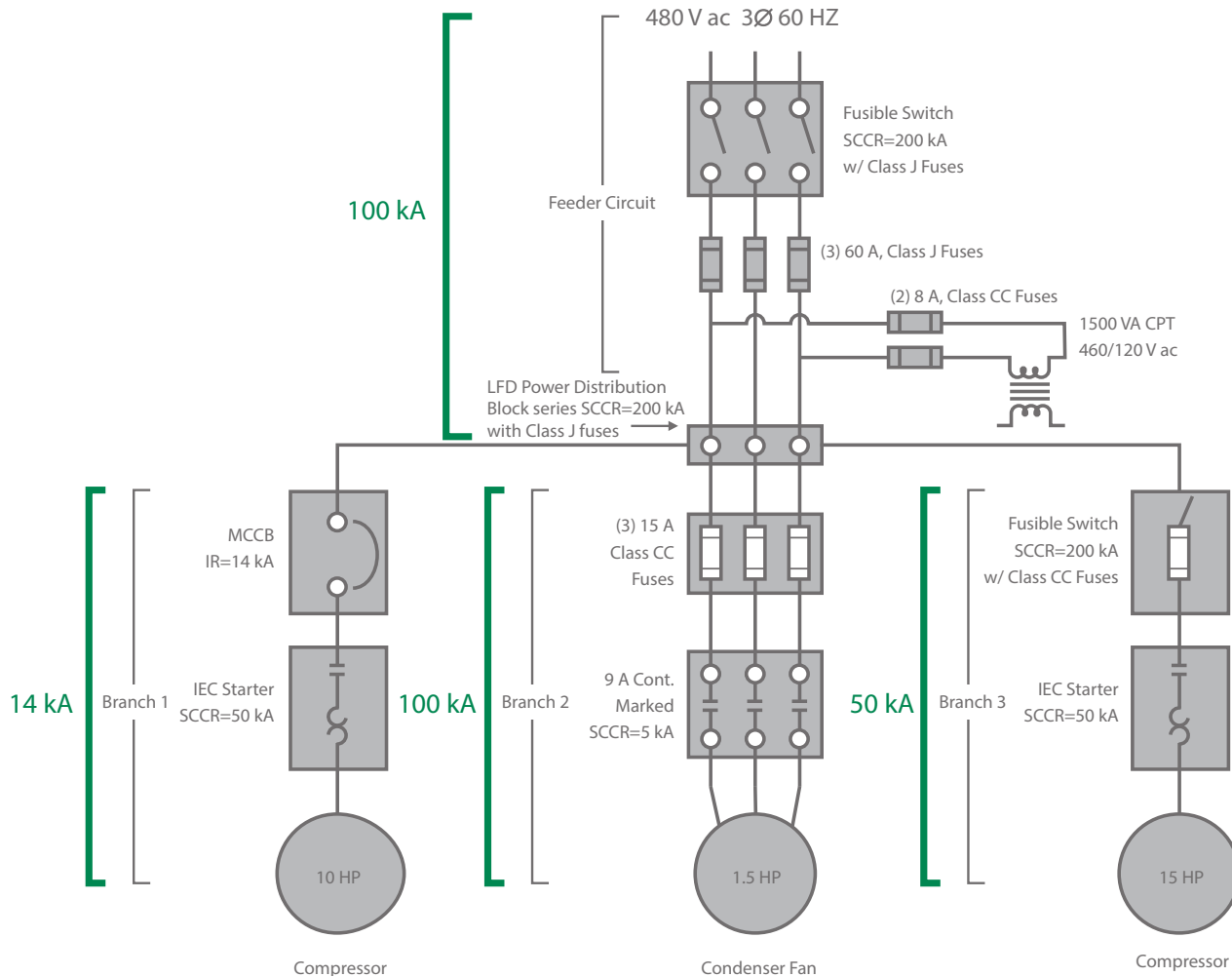

Figure 5. A standard industrial control panel.

However, if the branch circuit contains any circuit breakers or fuses that are in series with the current-limiting fuse (see **Figure 5**), then care must be taken to ensure that the current-limiting feeder fuse's threshold current will not be greater than the interrupting rating of any non-current-limiting overcurrent devices in the branch circuit.

In this example, the threshold current of the 60-ampere Class J fuse is about 1,000 amperes, which is significantly less than the interrupting rating of the 14 kA circuit breaker in Branch Circuit #1.

Based on the peak let-through charts, the SCCR of this panel will be an estimated minimum of 60,000 amperes, so long as [60-ampere Littelfuse JTD_ID Class J fuses](#) are used. In fact, if the available symmetrical rms fault current is 200 kA, then the fuses will limit the apparent rms fault current to only 4,000 amperes, safely protecting every component in the panel.

How Is the Overall SCCR of a Panel Determined?

NEC Article 409.110 states that the SCCR of an ICP is based on either the SCCR of a Listed and Labeled assembly or by utilizing an approved method. The article lists UL 508 A Supplement SB as one of these approved methods.

Some original-equipment manufacturers prefer to submit a panel to UL or to another NRTL to be tested and Listed if the panel is used for a specific purpose and continuously manufactured, or if the panel is part of a larger piece of Listed equipment.

Another reason to submit a panel for approval testing may be to obtain higher SCCRs than other approved methods can provide.

ANSI/UL 508A Supplement SB

ANSI/UL 508A Supplement SB provides an approved method to determine the ICP's SCCR by analyzing the components in the ICP. This method finds the panel's overall SCCR by looking at the SCCRs of each individual component within the panel and at the types of current-limiting power devices that are used within the panel.

The UL 508A Supplement SB method does not require the panel to be Listed. Since 2006, manufacturers of custom control panels that have the UL Listed certification mark have been required to follow the construction standards and the marking requirements of UL 508A Supplement SB.

Although UL 508A Supplement SB only refers to ICPs that are Listed, the standard's requirements can be applied to any control panel that provides power to any type of utilization equipment. Manufacturers who are only building a couple of panels at a time or who are producing panels with many different configurations often prefer to use UL 508A Supplement SB to establish the panel's SCCR.

UL 508A Supplement SB bases an ICP's SCCR on the types of overcurrent protective devices and the components' ratings in the panel. According to Supplement SB, an ICP's overall SCCR is the same as the SCCR of:

- the lowest rated component;
- the lowest rated UL approved series rated combination; and
- the SCCR of an approved series combination according to the standard.

However, the UL 508A Supplement SB method may not provide an adequate SCCR for the intended application. In these situations, the panel must be re-engineered or Listed and approved by a different method.

When panels with fuses and circuit breakers are Listed by an NRTL with a high fault SCCR, the equipment instructions and labels must indicate that overcurrent protective devices must be replaced only by a specified fuse class and rating, or by a specific make, model, and rating of a circuit breaker.

Panels that are not Listed may be scrutinized by the local electrical inspector or AHJ for the required NEC Article 409 SCCR markings. If requested by the local AHJ, manufacturers must keep detailed records of their bill of materials, SCCRs of all components, and the method that was used to determine the overall SCCR of the panel.

Panel Exercise

UL 508A Supplement SB4.1 provides three steps to determine the SCCR of ICPs.

1. Determine the SCCR of all individual power components that include UL-certified and approved series rated combinations.
2. Modify the SCCR of certain component combinations if current-limiting fuses are used in the feeder circuit.
3. Apply the lowest-rated SCCR of any power component, overcurrent protective device or modified combination to the SCCR of the panel.

Use the following example of a standard ICP to determine the panel's overall SCCR using the three steps in UL 508A Supplement SB4.1.

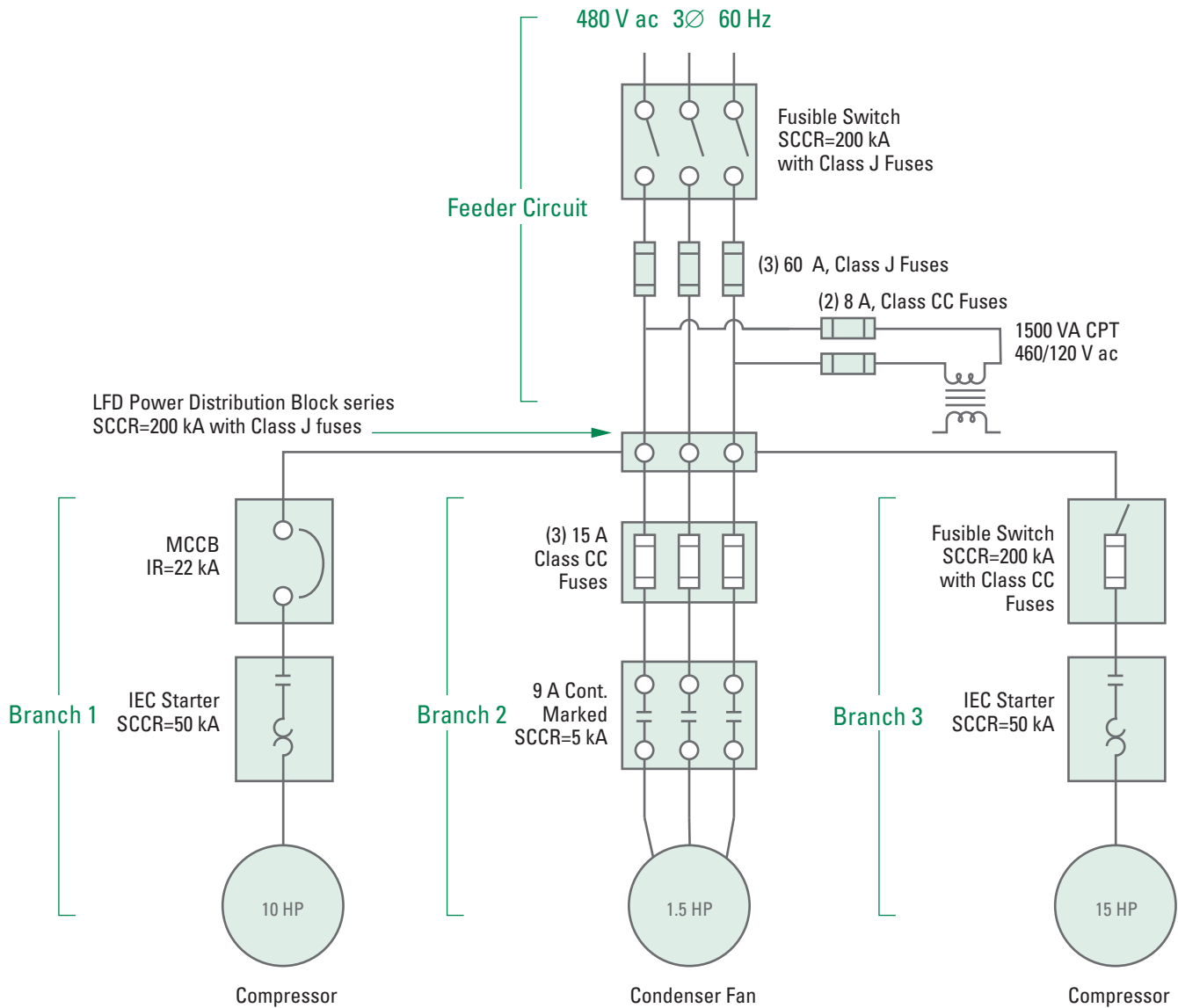

Figure 6. Panel prior to UL 508A Supplement SB method for determining SCCR.

How to Determine and Increase Short-Circuit Current Ratings for Industrial Control Panels

Step 1

Determine the SCCR of all individual power components that include UL-certified and approved series rated combinations.

All power components that are used to control and distribute power to individual motors, drives and other loads that are outside or inside the enclosure must be analyzed. Peripheral items such as current measuring transformers and items on the secondary side of current-limited control power transformers (including push buttons and contactor coils that are not in the direct power circuit paths) do not need to be analyzed.

If the SCCR or interrupting rating is not marked on the product, then check the product's literature and operating instructions. If a manufacturer has not provided the product's SCCR, then refer to **Table SB4.1** in UL 508A Supplement SB, which provides an assumed maximum SCCR for the device. All power components within the panel must be documented

and their SCCRs recorded.

Every power component in this example's power feeder circuit and branch circuits is marked with an SCCR or an IR.

After recording the SCCR of each power component in the panel and assigning SCCRs to unmarked components using **Table SB4.1**, it initially appears that the contactor in Branch Circuit #2 with its marked SCCR of 5 kA is the lowest-rated SCCR in the panel. However, certain combinations of power components with overcurrent protective devices (such as motor controllers with current-limiting fuses) may be UL certified and approved with a series rated SCCR that is higher than the lowest rated SCCR of any individual component. If any combination within the control panel is UL certified or Listed, then the SCCR of the approved series combination may be considered when determining a branch circuit's weakest link.

In this example, after consulting with both the manufacturer

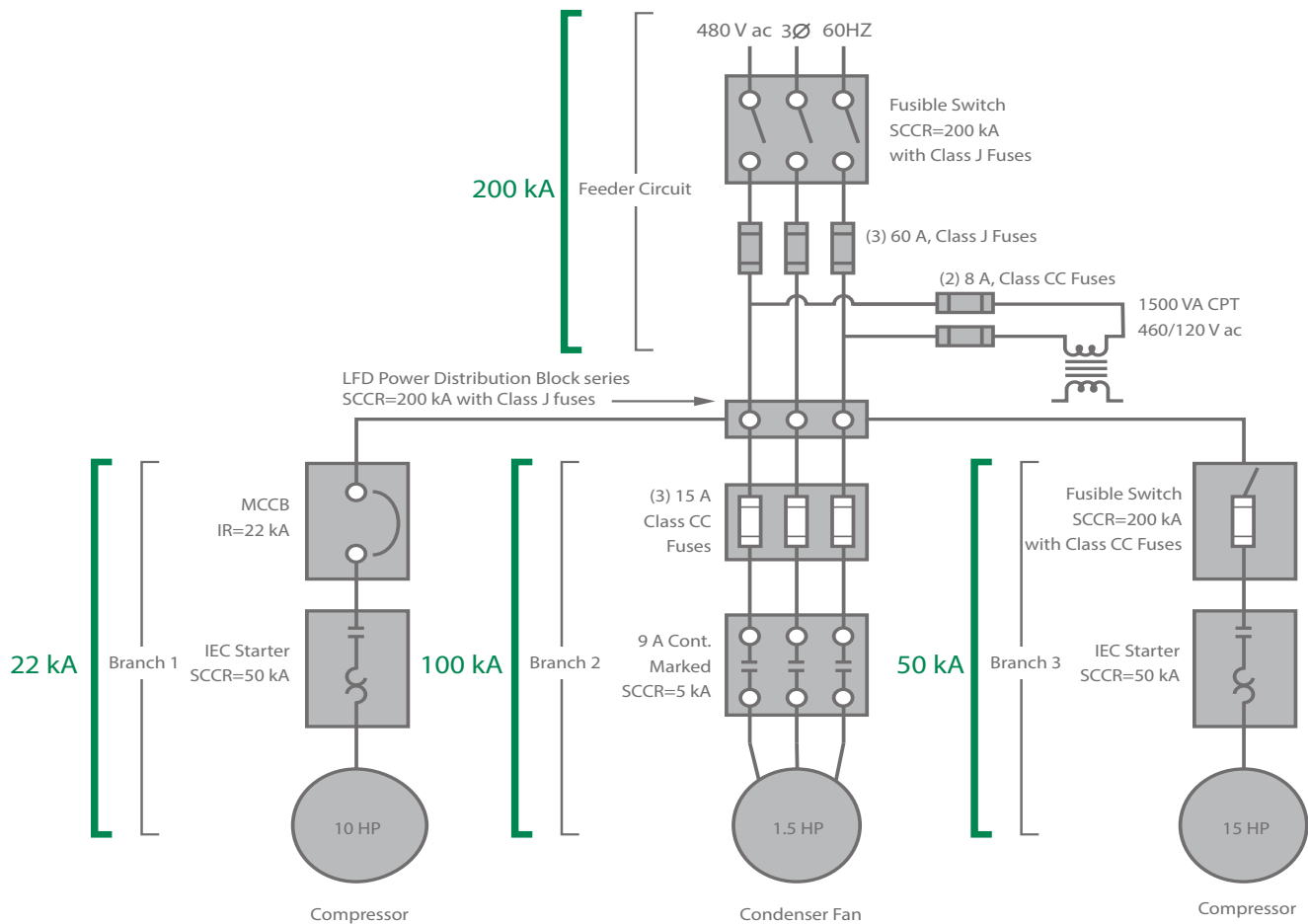

Figure 7. Panel after completion of step 1.

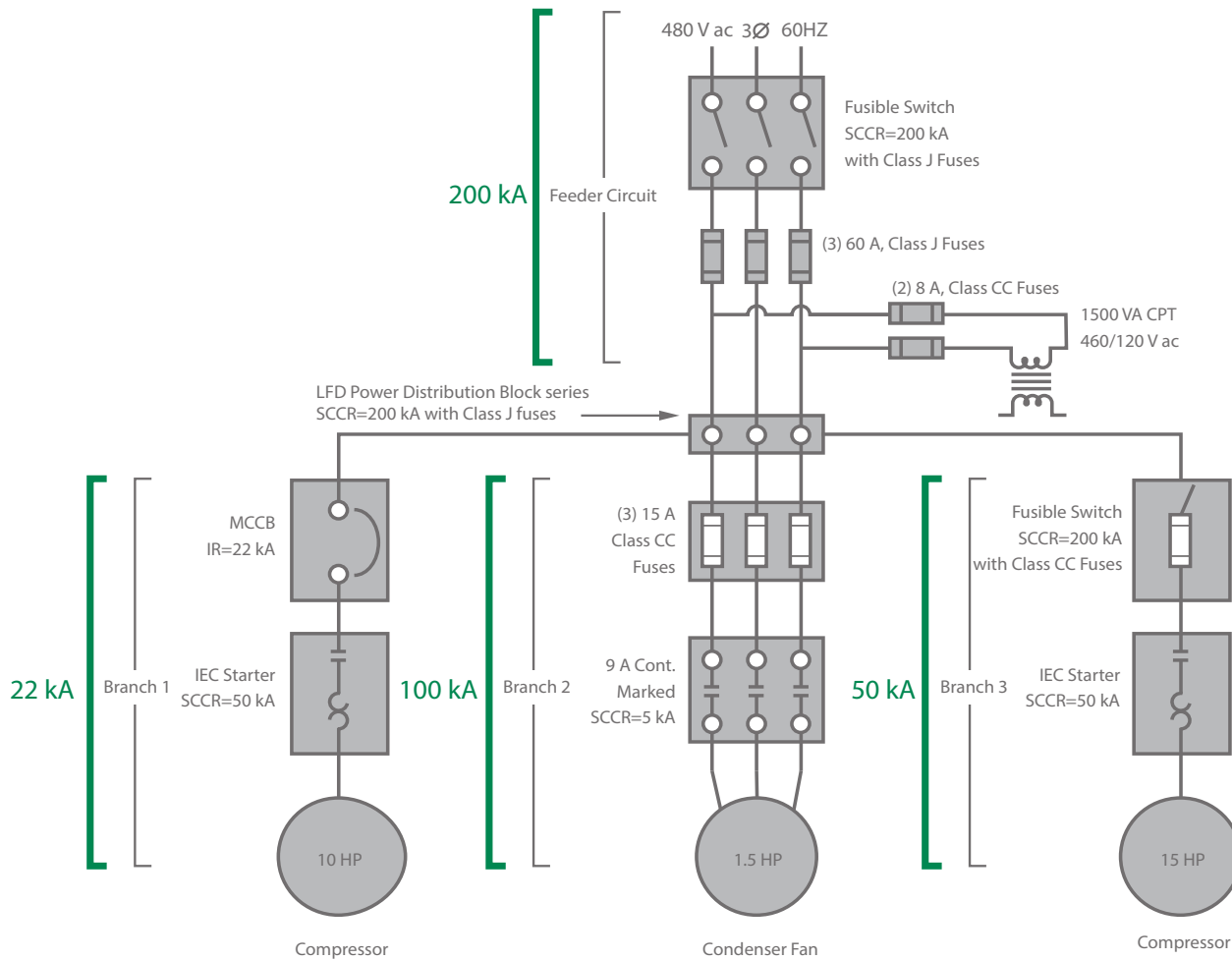

Figure 8. Panel after completion of step 2.

of the contactor from Branch Circuit #2 and with its UL listing documents, you learned that when the contactor is protected in series by UL Class CC or UL Class J fuses, it is UL -approved for Type 2 coordination with a series rated SCCR of 100 kA. This combination series rating not only increases the SCCR of the branch circuit but also ensures that the contactor will remain operable after a short circuit. Always consult the equipment manufacturer to verify UL approved series combination SCCRs and to learn of any special circumstances that may increase the SCCR of the panel.

When each component's SCCR, approved-series combination, and feeder and branch circuit is added to the panel diagram from **Figure 6**, the panel's diagram will look like the panel in **Figure 7**.

Step 1 revealed the SCCR of all individual power components:

- The SCCR of the Feeder Circuit is 200 kA.
- The minimum SCCR of Branch Circuit #1 is 22 kA due to the interrupting rating of the MCCB
- The SCCR of Branch Circuit #2 is 100 kA because of the approved series combination rating.
- The minimum SCCR of Branch Circuit #3 is 50 kA due to the IEC starter.

Step 2

Modify the SCCR of certain component combinations if current-limiting fuses are used in the feeder circuit.

UL 508A Supplement SB Article SB4.3 describes how feeder components such as current-limiting fuses can limit the peak let-through current within a panel. **Table SB4.2** of UL

Table SB4.1.2. Assumed maximum short circuit current rating for unmarked components.

COMPONENT	SHORT CIRCUIT CURRENT RATING in kA
Bus bars	10
Circuit breaker (including GFCIs)	5
Current meters	a
Current shunt	10
Fuse holder	10
Industrial control equipment:	
a. Auxiliary devices (overload relay)	5
b. Switches (other than mercury tube type)	5
c. Mercury tube switches	
Rated over 60 amperes or over 250 volts	5
Rated 250 volts or less, 60 amperes or less, and over 2 kVA	3.5
Rated 250 volts or less and 2 kVA or less	1
Motor controller, rated in horsepower (kW)	
a. 0 - 50 (0 - 37.3)	5 ^c
b. 51 - 200 (38 - 149)	10 ^c
c. 201 - 400 (150 - 298)	18 ^c
d. 401 - 600 (299 - 447)	30 ^c
e. 601 - 900 (448 - 671)	42 ^c
f. 901 - 1500 (672 - 1193)	85 ^c
Meter socket base	10
Miniature or miscellaneous fuse	10 ^b
Receptacle (GFCI)	2
Receptacle (other than GFCIs)	10
Supplementary protector	0.2
Switch unit	5
Terminal block or power distribution block	10

^a An SCCR is not required when connected through a current transformer or current shunt. A directly connected current meter shall have a marked SCCR.

^b The use of a miniature fuse is limited to 125-volt circuits.

^c Standard fault current rating for motor controller rated within specified horsepower range.

508A Supplement SB (see **Figure 8**) lists the UL maximum allowable instantaneous peak let-through currents and the maximum allowable clearing I^2t for UL Class current-limiting fuses at different levels of available rms fault current (50 kA, 100 kA, or 200 kA). All manufacturers of UL approved current-limiting fuses must limit the I_{peak} and the I^2t to the maximum values provided in the table. UL 508A Supplement SB uses the I_{peak} values that are listed in **Table SB4.2** to determine the fuse's ability to limit the peak let-through current to branch circuits within the panel.

If the feeder fuse's I_{peak} is less than or equal to the lowest-rated SCCR of any passive component in the branch circuit, then the SCCR of the combination is the available rms current at which the fuse limits the peak current.

The modifications made in step 2 only apply to current-limiting devices in the feeder circuit that have passive (nonovercurrent protective) devices in branch circuits.

Based on **Table SB4.2**, the 60-ampere UL Class J fuse will limit the I_{peak} to 16 kA or less if there is a 200 kA available fault current.

An available fault current that is more than the overcurrent device's interrupting rating but less than 200 kA can cause any present branch circuit overcurrent devices to open before the feeder fuse clears the circuit. This is hazardous. Therefore, the panel's SCCR may not be more than the lowest interrupting rating of any fuse or circuit breaker in the panel unless it is tested and listed by an NRTL.

Step 2 determined the following information (see **Figure 8**):

- The SCCR of the Feeder Circuit and power distribution block is 200 kA.
- The minimum SCCR of Branch Circuit #1 is 22 kA (due to the MCCB).
- The SCCR of Branch Circuit #2 is 100 kA.
- The minimum SCCR of Branch Circuit #3 is 50 kA (due to the IEC starter).

UL 508A Article SB3.2 requires branch circuit overcurrent protection for control circuits that are tapped off the feeder circuit (see **Figure 6**). The interrupting rating of the branch circuit fuse or circuit breaker must also be equal to or greater than the overall SCCR of the panel. Furthermore, the branch circuit fuse or the circuit breaker's interrupting rating must be equal to or greater than the overall SCCR of the panel.

With a marked interrupting rating of 200 kA, the 8-ampere

control circuit fuses in this example, which are branch-circuit UL Class CC fuses, comply with UL 508A Article SB3.2.

Supplementary fuses and protectors are not permitted to be located on the primary side of a control circuit.

Step 3

Apply the lowest-rated SCCR of any power component, overcurrent protective device or modified combination to the SCCR of the panel.

This example panel's SCCR is based on the lowest-rated SCCR of any power component not modified in step 2, the lowest rated SCCR in any branch circuit, and the lowest-rated interrupting rating of any overcurrent protective device.

Branch Circuit #1's lowest-rated SCCR is 22 kA.

The SCCR of the entire panel is 22 kA. This is based on the breaker's IR.

How to Increase the SCCR of Industrial Control Panels

To increase the SCCR of an ICP:

- Use components or approved combinations with high SCCRs.
- Use current-limiting fuses (or another type of current-limiting device) in the feeder circuit (refer to UL 508A Supplement SB for more information).
- Use overcurrent protective devices with higher interrupting ratings in branch and control circuits.
- Submit the panel to UL or another NRTL for approval testing utilizing the "Tested Method."

UL 508A Supplement SB assigns a maximum SCCR of only 200 amperes to unmarked supplementary protectors. UL 508A Article SB3.2 does not allow supplementary protectors in primary control circuits. If any supplementary protectors are used in branch circuits, replacing the supplementary protector with Littelfuse UL Class CC fuses in touch-safe DIN rail mounted fuse holders can dramatically increase the SCCR of an industrial control panel and, in turn, increase safety.

Littelfuse also offers LD Series Distribution Blocks and LS Series Splicer Blocks which are UL Listed and have a higher SCCR when used with current-limiting fuses that increase the SCCR of an industrial control panel.

How to Determine and Increase Short-Circuit Current Ratings for Industrial Control Panels

UL 508A Table SB4.2. Fuse Peak let through currents, I_p , and clearing, I^2t , based on available short circuit current levels.

FUSE TYPES	FUSE RATING AMPERES	BETWEEN THRESHOLD AND 50 kA		100 kA		200 kA	
		$I^2t \times 10^3$	$I_p \times 10^3$	$I^2t \times 10^3$	$I_p \times 10^3$	$I^2t \times 10^3$	$I_p \times 10^3$
Class CC	15	2	3	2	3	3	4
	20	2	3	3	4	3	5
	30	7	6	7	7.5	7	12
Class G	15	-	-	3.8	4	-	-
	20	-	-	5	5	-	-
	30	-	-	7	7	-	-
	60	-	-	25	10.5	-	-
300 volt Class T^b	1	-	-	0.4	0.8	-	-
	3	-	-	0.6	1.3	-	-
	6	-	-	1	2	-	-
	10	-	-	1.5	3	-	-
	15	-	-	2	4	-	-
	20	-	-	2.5	4.5	-	-
	25	-	-	2.7	5.5	-	-
	30	3.5	5	3.5	7	3.5	9
	35	-	-	6	7	-	-
	40	-	-	8.5	7.2	-	-
	45	-	-	9	7.6	-	-
	50	-	-	11	8	-	-
	60	15	7	15	9	15	12
	70	-	-	25	10	-	-
	80	-	-	30	10.7	-	-
	90	-	-	38	11.6	-	-
	100	40	9	40	12	40	12
	110	-	-	50	12	-	-
	125	-	-	75	13	-	-
	150	-	-	88	14	-	-
	175	-	-	115	15	-	-
	200	150	13	150	16	150	20
	225	-	-	175	21	-	-
	250	-	-	225	22	-	-
300	-	-	300	24	-	-	
350	-	-	400	27	-	-	
400	500	22	550	28	550	35	
450	-	-	600	32	-	-	
500	-	-	800	37	-	-	
600	1000	29	1000	37	1000	46	
700	-	-	1250	45	-	-	
800	1500	37	1500	50	1500	65	
1000	-	-	3500	65	-	-	
1200	3500	50	3500	65	4000	80	

How to Determine and Increase Short-Circuit Current Ratings for Industrial Control Panels

FUSE TYPES	FUSE RATING AMPERES	BETWEEN THRESHOLD AND 50 kA		100 kA		200 kA	
		$I^2t \times 10^3$	$I_p \times 10^3$	$I^2t \times 10^3$	$I_p \times 10^3$	$I^2t \times 10^3$	$I_p \times 10^3$
Class CF (up to 100 A), Class J, and 600 volt Class T ^b	1	-	-	0.8	1	-	-
	3	-	-	1.2	1.5	-	-
	6	-	-	2	2.3	-	-
	10	-	-	3	3.3	-	-
	15	-	-	4	4	-	-
	20	-	-	5	5	-	-
	25	-	-	5.5	6	-	-
	30	7	6	7	7.5	7	12
	35	-	-	12	7.5	-	-
	40	-	-	17	8	-	-
	45	-	-	18	8.5	-	-
	50	-	-	22	9	-	-
	60	30	8	30	10	30	16
	70	-	-	50	11.5	-	-
	80	-	-	60	12.5	-	-
	90	-	-	75	13.5	-	-
	100	60	12	80	14	80	20
	110	-	-	100	14.5	-	-
	125	-	-	150	15.5	-	-
	150	-	-	175	17	-	-
	175	-	-	225	18.5	-	-
	200	200	16	300	20	300	30
	225	-	-	350	22.5	-	-
	250	-	-	450	24	-	-
	300	-	-	600	26	-	-
	350	-	-	800	29	-	-
	400	1000	25	1100	30	1100	45
	450	-	-	1500	36	-	-
500	-	-	2000	42	-	-	
600	2500	35	2500	45	2500	70	
700	-	-	1200	45	-	-	
800a	4000	50	4000	55	4000	75	

^a Value applies to Class T fuses.

^b When values at 50 kA and 200 kA are needed, the standard case size shall be used.

How to Determine and Increase Short-Circuit Current Ratings for Industrial Control Panels

FUZE TYPES	FUZE RATING AMPERES	BETWEEN THRESHOLD AND 50 kA		100 kA		200 kA							
		$I^2t \times 10^3$	$I_p \times 10^3$	$I^2t \times 10^3$	$I_p \times 10^3$	$I^2t \times 10^3$	$I_p \times 10^3$						
Class L	800	10000	80	10000	80	10000	80						
	1200	12000	80	12000	80	15000	120						
	1600	22000	100	22000	100	30000	150						
	2000	35000	110	35000	120	40000	165						
	2500	-	-	75000	165	75000	180						
	3000	-	-	100000	175	10000	200						
	4000	-	-	150000	220	150000	250						
	5000	-	-	350000	-	350000	300						
	6000	-	-	350000	-	500000	350						
Class R		RK1	RK5	RK1	RK5	RK1	RK5	RK1	RK5	RK1	RK5	RK1	RK5
	30	10	50	6	11	10	50	10	11	11	50	12	14
	60	200	200	10	20	40	200	12	21	50	200	16	26
	100	500	500	14	22	100	500	16	25	100	500	20	32
	200	1600	1600	18	32	400	1600	22	40	400	2000	30	50
	400	5000	5000	33	50	1200	5000	35	60	1600	6000	50	75
	600	10000	10000	43	65	3000	10000	50	80	4000	12000	70	100

Summary

Safety is the byproduct of a well-crafted design. SCCR labeling requirements create safe installations. Panel designers must be knowledgeable about SCCR and how to optimize SCCR ratings to build the most effective panel.

- All ICPs must be marked with an SCCR.
- Panels can be submitted and tested by an NRTL to establish the SCCR.
- UL 508A Supplement SB may be used to establish the SCCR.
- Using current-limiting fuses is one of the easiest ways to increase the SCCR of a panel.
- Current-limiting fuses increase safety and reliability.

To maintain the marked SCCR, warning labels and instructions must clearly indicate that overcurrent protective devices may only be replaced with the specific components that were originally designed for the application.

Littelfuse Inc. offers a complete line of current-limiting fuses and accessories to increase the SCCR of ICPs and reduce arc flash and other electrical hazards for electrical workers.

Refer to the [Littelfuse SCCR Center](#) for more information.

Endnotes

*The National Electrical Code is a trademark of the National Fire Protection Association. With the permission of Underwriters Laboratories, Inc., material is reproduced from UL Standard 508A, Standard For ICPs, which is copyrighted by Underwriters Laboratories, Inc., 333 Pfingsten Road, Northbrook Illinois 60062. UL shall not be responsible to anyone for the use of or reliance upon a UL Standard by anyone. UL shall not incur any obligation or liability for damages, including consequential damages, arising out of or in connection with the use, interpretation of, or reliance upon a UL Standard. UL's Standards for Safety are copyrighted by UL. Neither a printed copy of a Standard, nor the file for an electronic version of a Standard may be copied, reproduced, and/or altered in any way. All of UL's Standards and all copyrights, ownerships, and rights regarding those Standards shall remain the sole and exclusive property of UL.

Revisions of UL Standards for Safety are issued from time to time. A UL Standard for Safety is current only if it incorporates the most recently adopted revisions.

For more information on purchasing copies of UL 508A, visit www.UL.com.

For more information, about NEC Article 409, UL 508A and products that can increase the SCCR and safety of industrial control panels, please contact the Littelfuse Technical Support and Engineering Services Group at techline@littelfuse.com or (800) TEC-FUSE, or go to www.littelfuse.com/SCCR.

Terms and Definitions

Current-Limiting Overcurrent Protective Device: A device that, when interrupting currents in its current-limiting range, reduces the current flowing in the faulted circuit to a magnitude substantially less than that obtainable in the same circuit if the device were replaced with a solid conductor having comparable impedance.

Current Limiting Range: For an individual overcurrent protective device, the current-limiting range begins at the lowest value of rms symmetrical current at which the device becomes current-limiting (the threshold current) and extends to the maximum interrupting capacity of the device.

Fault Current: The current that flows when a phase conductor is faulted to another phase or ground.

Industrial Control Panel : An assembly of two or more components consisting of one of the following: (1) power circuit components only, such as motor controllers, overload relays, fused disconnect switches, and circuit breakers; (2) control circuit components only, such as push buttons, pilot lights, selector switches, timers, switches, and control relays; (3) a selector switches, timers, switches, and control relays; (3) a combination of power and control circuit components.

Instantaneous Current: The amount of charge that passes through a conductor.

Instantaneous Peak Current (I_{peak}): The maximum instantaneous current value developed during the first half-cycle (180 electrical degrees) after fault inception. The peak current determines magnetic stress within the circuit.

Interrupting Capacity: The maximum fault current that can be interrupted by a circuit breaker without failure of the circuit breaker.

Interrupting Rating: The highest rms symmetrical current, at specified test conditions, which the device is rated to interrupt. The difference between interrupting capacity and interrupting rating is in the test circuits used to establish the ratings.

rms (Root Mean Squared) Current: Effective current value for a given ac wave obtained through mathematical method. The rms value of ac is equivalent to the value of dc which would produce the same amount of heat or power. The mathematical expression of rms current corresponds to the peak instantaneous value of a ac waveform divided by the square root of two.

Short Circuit: Any current in excess of the rated current of equipment or the ampacity of the conductor. This may result from overload, short circuit, or ground fault. A current flowing outside its normal path, which is caused by a breakdown of insulation or by faulty equipment connections. In a short-circuit, current bypasses the normal load. Current is determined by the system impedance (ac resistance) rather than the load impedance. Short-circuit currents may vary from fractions of an ampere to 200,000 amperes or more. If not removed promptly, large overcurrents associated with a short-circuit can have three profound effects on an electrical system: heating, magnetic stress and arcing.

Short-Circuit Current Rating: The prospective symmetrical fault current at a nominal voltage to which an apparatus or system is able to be connected without sustaining damage exceeding defined acceptance criteria.

Threshold Current: The minimum current for a given fuse size and type at which the fuse becomes current-limiting.

Voltage: The greatest root-mean-square (rms) (effective) difference of potential between any two conductors of the circuit concerned.