

IXD2012N

High-Side and Low-Side Gate Driver

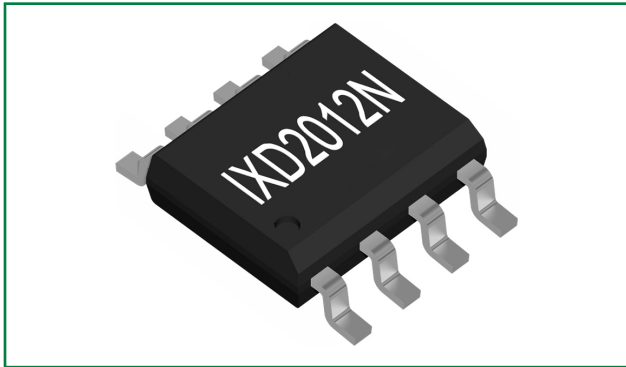

Features

- Floating high-side driver up to 200V in bootstrap configuration
- Drives two N-channel MOSFETs or IGBTs in a half-bridge configuration
- 1.9A source / 2.3A sink output current capability
- Outputs tolerant to negative transients
- 10V to 20V low-side gate driver supply voltage
- Logic input (HIN and LIN) 3.3V compatible
- Schmitt trigger logic inputs with internal pull down
- Under Voltage Lockout (UVLO) for high-side and low-side drivers
- Ambient operating temperature range: -40°C to $+125^{\circ}\text{C}$

Applications

- DC-DC Converters
- AC-DC Inverters
- Motor Controls
- Class-D Power Amplifiers

IXD2012N Simplified Application Circuit

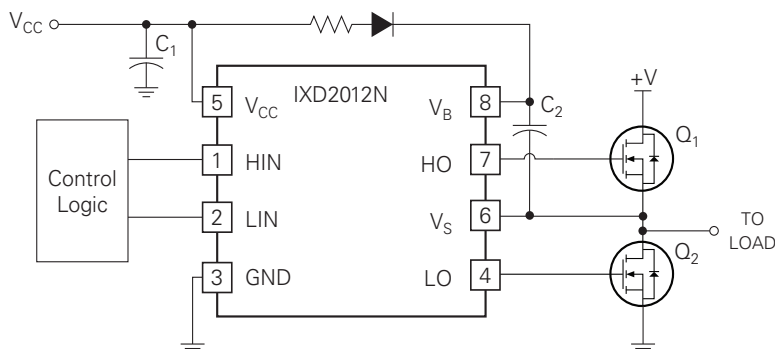

Description



The IXD2012N is a high-side and low-side, high-speed gate driver capable of driving N-channel MOSFETs and IGBTs in a half bridge configuration. The process technology enables the IXD2012N's high-side to switch up to 200V in a bootstrap operation.

The IXD2012N logic inputs are standard TTL and CMOS logic level compatible to interface easily with controlling devices. The driver has integrated cross-conduction protection logic, which prevents the high-side and low-side outputs to turn on at the same time.

The IXD2012N is offered in a SOIC(N)-8 package on tape and reel, and its operating ambient temperature rating is -40°C to $+125^{\circ}\text{C}$.

Ordering Information

Part Number	Description
IXD2012NTR	SOIC(N)-8, Tape and Reel, 2500 / reel

1 Specifications	3
1.1 Package Pinout	3
1.2 Pin Description	3
1.3 Absolute Maximum Ratings	3
1.4 Recommended Operating Conditions	4
1.5 Electrical Characteristics	4
1.6 Timing Characteristics	5
1.7 Timing Waveforms	5
1.8 Thermal Characteristics	5
2 Functional Description	6
2.1 Functional Block Diagram	6
2.2 Stepper Motor Driver Application Example	6
3 Manufacturing Information	7
3.1 Moisture Sensitivity	7
3.2 ESD Sensitivity	7
3.3 Soldering Profile	7
3.4 Board Wash	7
3.5 Mechanical Dimensions	8
3.5.1 IXD2012N SOIC(N)-8 Package	8
3.5.2 IXD2012N SOIC(N)-8 Package Tape and Reel	8

1 Specifications

1.1 Package Pinout

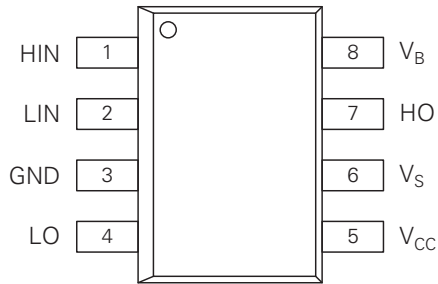

1.2 Pin Description

Pin	Name	Type	Description
1	HIN	Input	Logic input for high-side gate driver control, non-inverting
2	LIN	Input	Logic input for Low-side gate driver control, non-inverting
3	GND	Power	Low-side and logic return
4	LO	Output	Low-side gate drive output
5	V _{CC}	Power	Low-side and logic supply
6	V _S	Power	High-side floating supply return
7	HO	Output	High-side gate drive output
8	V _B	Power	High-side floating supply

1.3 Absolute Maximum Ratings

Parameter	Symbol	Value		Units
		Minimum	Maximum	
High-side floating supply voltage	V _B	-0.3	224	V
High-side floating supply offset voltage	V _S	V _B - 24	V _B + 0.3	
High-side floating output voltage	V _{HO}	V _S - 0.3	V _B + 0.3	
Offset supply voltage transient	dV _S /dt	—	50	V/ns
Low-side fixed supply voltage	V _{CC}	-0.3	24	V
Low-side output voltage	V _{LO}	-0.3	V _{CC} + 0.3	
Logic input voltage (HIN and LIN)	V _{IN}	-0.3	V _{CC} + 0.3	
Package power dissipation	P _D	—	0.625	W
Junction operating temperature	T _J	—	150	°C
Storage temperature	T _{STG}	-55	150	

Unless otherwise specified all voltages are referenced to GND. Electrical and power ratings are at T_A = 25°C. Power dissipation rating is in still air while mounted on a standard JEDEC 2-layer FR-4 board.

1.4 Recommended Operating Conditions

Unless otherwise specified, all voltages are referenced to GND.

Parameter	Symbol	Value		Units
		Minimum	Maximum	
High-side floating supply voltage	V_B	$V_S + 10$	$V_S + 20$	V
High-side floating supply offset voltage ¹	V_S	—	200	
High-side floating output voltage	V_{HO}	V_S	V_B	
Low-side fixed supply voltage	V_{CC}	10	20	
Low-side output voltage	V_{LO}	0	V_{CC}	
Logic input voltage (HIN and LIN)	V_{IN}	0	5	
Ambient operating temperature	T_A	-40	125	°C

¹ High-side driver remains operational for ambient operating temperature down to -5V.

1.5 Electrical Characteristics

Unless otherwise specified, $V_{CC} = V_{BS} = 15V$, $GND = 0V$ and $T_A = 25^\circ C$.

The V_{IN} and I_{IN} parameters are applicable to both logic input pins: HIN and LIN. The V_O and I_O parameters are applicable to the respective output pins: HO and LO and are referenced to GND.

Parameter	Symbol	Conditions	Value			Units
			Minimum	Typical	Maximum	
Input voltage						
Logic "1"	V_{IH}	$V_{CC} = 10V \text{ to } 20V$ ¹	2.5	—	—	V
Logic "0"	V_{IL}		—	—	0.8	
Hysteresis	$V_{IN(HYS)}$		—	0.3	—	
High level output voltage, $V_{BIAS} - V_O$	V_{OH}	$I_O = 0A$	—	—	1.4	
Low level output voltage, V_O	V_{OL}	$I_O = 20mA$	—	—	0.2	
Offset supply leakage current	I_{LK}	$V_B = V_S = 200V$	—	—	50	μA
Quiescent supply current						
V_{BS}	I_{BSQ}	$V_{IN} = 0V \text{ or } 5V$	20	60	150	μA
V_{CC}	I_{CCQ}	$V_{IN} = 0V \text{ or } 5V$	50	120	240	
Input bias current						
Logic "1"	I_{IN+}	$V_{IN} = 5V$	—	25	60	μA
Logic "0"	I_{IN-}	$V_{IN} = 0V$	—	—	5	
V_{BS} UVLO						
Off, positive going threshold	V_{BSUV+}	—	7.0	8.9	9.8	V
Enable, negative going threshold	V_{BSUV-}	—	6.4	8.2	9.0	
Hysteresis	$V_{BSUV(HYS)}$	—	—	0.7	—	
V_{CC} UVLO						
Off, positive going threshold	V_{CCUV+}	—	7.0	8.9	9.8	V
Enable, negative going threshold	V_{CCUV-}	—	6.4	8.2	9.0	
Voltage hysteresis	$V_{CCUV(HYS)}$	—	—	0.7	—	
Output short circuit pulsed current						
High	I_{O+}	$V_O = 0V, t \leq 10\mu s$	1.4	1.9	—	A
Low	I_{O-}	$V_O = 15V, t \leq 10\mu s$	1.8	2.3	—	

¹ For optimal operation, it is highly recommended to apply input pulses to HIN and LIN with a pulse width of at least 400ns.

1.6 Timing Characteristics

Unless otherwise specified, $V_{CC}=V_{BS}=15V$, $C_L=1\text{ nF}$, and $T_A=25^\circ\text{C}$.

Parameter	Symbol	Conditions	Value			Units
			Minimum	Typical	Maximum	
Turn-on propagation delay	t_{on}	$V_S=0V$	—	180	270	ns
Turn-off propagation delay	t_{off}	$V_S=0V$ or $200V$	—	220	330	
Propagation delay matching, HO and LO turn-on/off	t_{DM}	—	—	—	35	
Turn-on rise time	t_r	$V_S=0V$	—	30	60	
Turn-off fall time	t_f		—	20	35	

1.7 Timing Waveforms

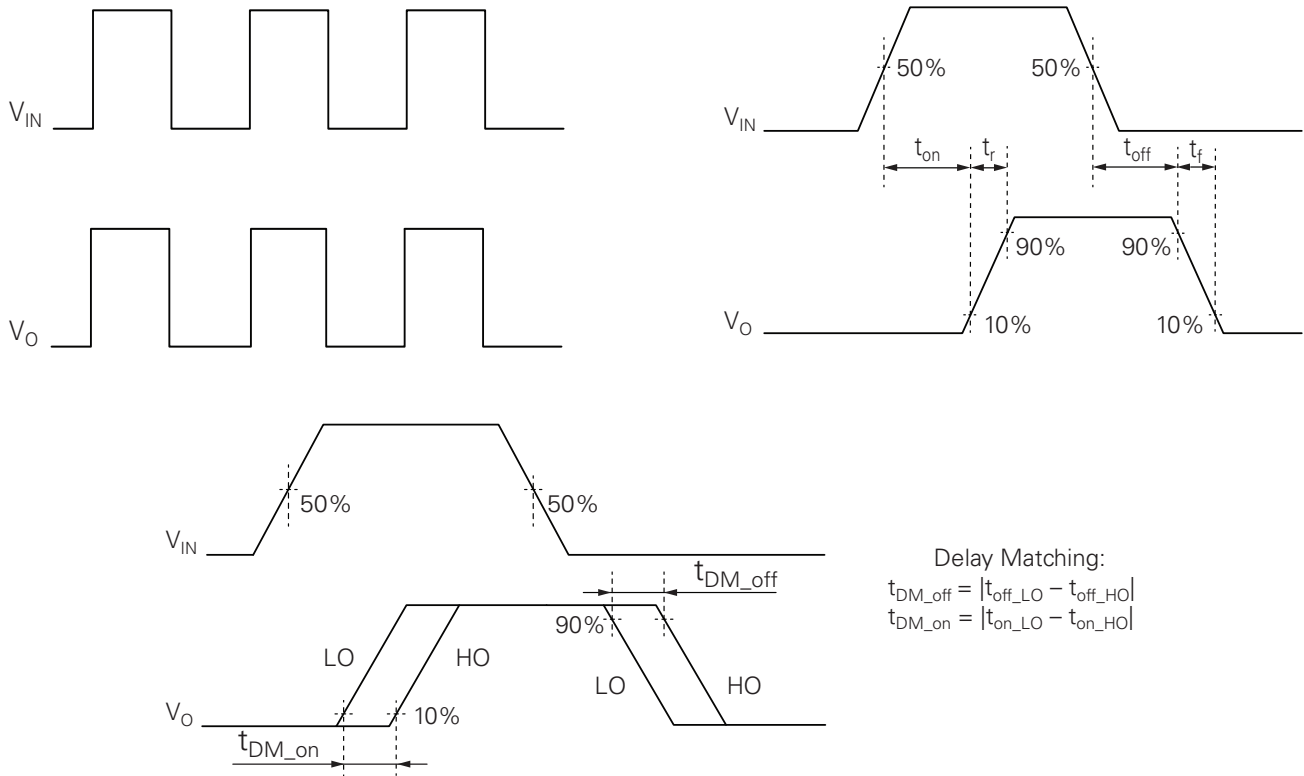

1.8 Thermal Characteristics

Parameter	Symbol	Rating	Units
Thermal Impedance, Junction to Ambient	θ_{JA}	200	K/W

Measured in still air while mounted on a standard JEDEC 2-layer FR-4 board.

2 Functional Description

2.1 Functional Block Diagram

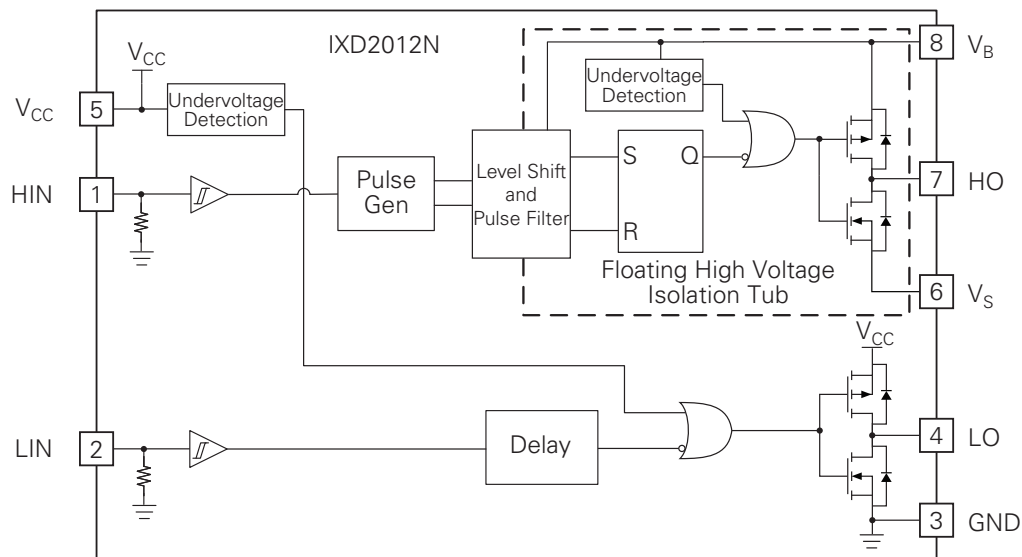

2.2 Stepper Motor Driver Application Example

Below circuit schematic shows one phase-leg of a four leg dual H-bridge stepper motor driver circuit.

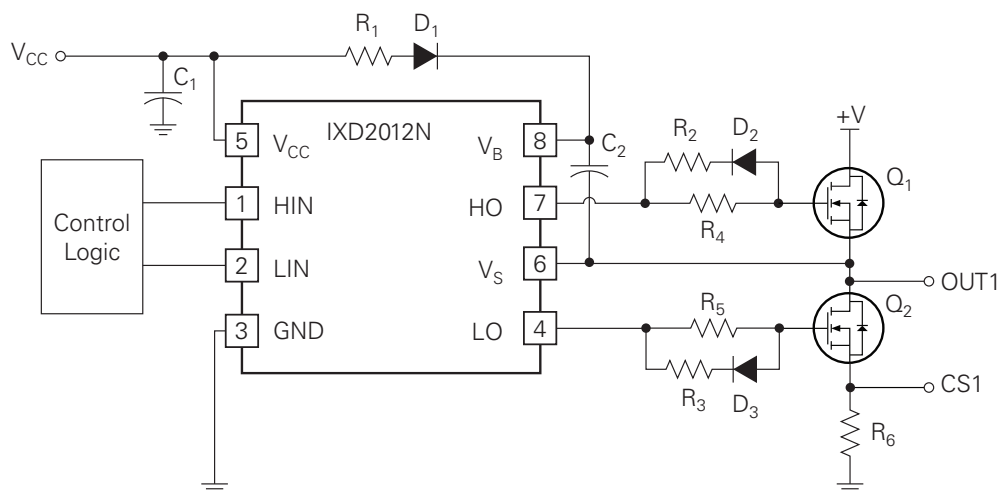

- R_2 and R_3 values are typically between 0Ω and 10Ω , with the exact value determined by the MOSFET junction capacitance and gate driver sink current.
- R_4 and R_5 values are typically between 10Ω and 100Ω , with the exact value determined by the MOSFET junction capacitance and gate driver output current.
- R_1 is typically between 3Ω and 20Ω , with the exact value depending on the bootstrap capacitor value and the amount of current limiting required for the bootstrap diode. Also, D_1 should be an ultrafast diode with a minimum current rating of 1 A and a voltage rating higher than the system operating voltage.
- OUT1 connected to stepping motor coil.
- R_6 is used to sense current and convert it to voltage. The current sense node, CS1 is connected to comparator and Input Logic control.
- It is recommended that the input pulses, HIN and LIN, have a minimum amplitude of 2.5 V (for $V_{CC} = 15\text{V}$) and a minimum pulse width of 400 ns.

3 Manufacturing Information

3.1 Moisture Sensitivity



All plastic encapsulated semiconductor packages are susceptible to moisture ingress. Littelfuse classifies its plastic encapsulated devices for moisture sensitivity according to the latest version of the joint industry standard, **IPC/JEDEC J-STD-020**, in force at the time of product evaluation. We test all of our products to the maximum conditions set forth in the standard, and guarantee proper operation of our devices when handled according to the limitations and information in that standard as well as to any limitations set forth in the information or standards referenced below.

Failure to adhere to the warnings or limitations as established by the listed specifications could result in reduced product performance, reduction of operable life, and/or reduction of overall reliability.

This product carries a Moisture Sensitivity Level (MSL) classification as shown below, and should be handled according to the requirements of the latest version of the joint industry standard **IPC/JEDEC J-STD-033**.

Device	Moisture Sensitivity Level (MSL) Classification
IXD2012N	MSL 3

3.2 ESD Sensitivity



This product is ESD Sensitive, and should be handled according to the industry standard **JESD-625**.

3.3 Soldering Profile

Provided in the table below is the **IPC/JEDEC J-STD-020** Classification Temperature (T_c) and the maximum dwell time ($T_c - 5$ °C). The Classification Temperature sets the Maximum Body Temperature allowed for these devices, during reflow soldering processes.

Device	Classification Temperature (T_c)	Dwell Time (t_p)	Maximum Reflow Cycles
IXD2012N	260 °C	30 seconds	3

3.4 Board Wash

Littelfuse recommends the use of no-clean flux formulations. Board washing to reduce, or remove flux residue following the solder reflow process is acceptable, provided proper precautions are taken to prevent damage to the device. These precautions include, but are not limited to: Using a low pressure wash and providing a follow-up bake cycle sufficient to remove any moisture trapped within the device, due to the washing process. Due to the variability of the wash parameters used to clean the board, determination of the bake temperature and duration necessary to remove the moisture trapped within the package is the responsibility of the user (assembler). Cleaning, or drying methods that employ ultrasonic energy may damage the device and should not be used. Additionally, the device must not be exposed to halide flux or solvents.



3.5 Mechanical Dimensions

3.5.1 IXD2012N SOIC(N)-8 Package

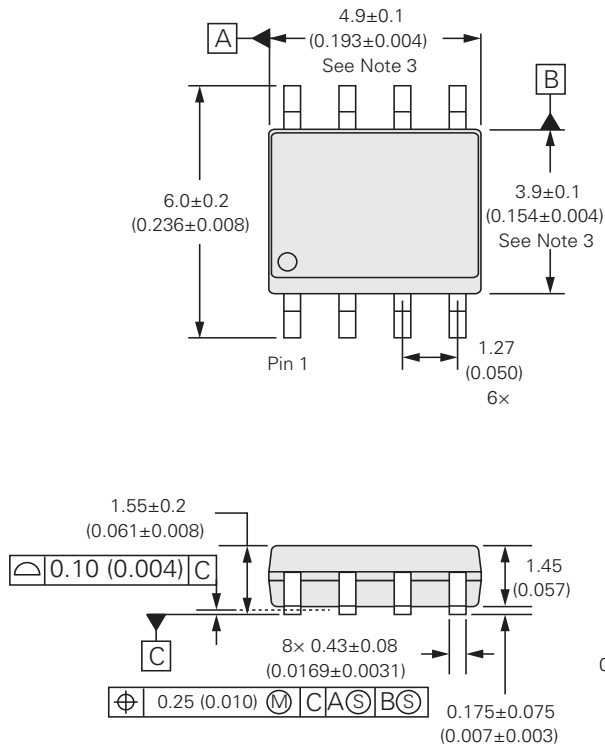

Recommended PCB Land Pattern

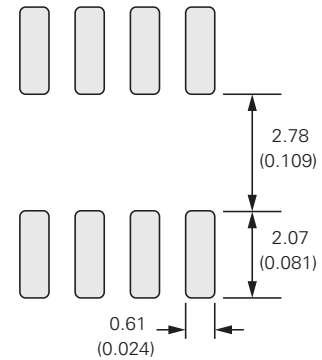

Notes:

1. Controlling dimension: millimeters.
2. Reference JEDEC registration MS-012, variation AA.
3. Not including mold flash, protrusion, or gate burrs 0.15 (0.006) maximum per end.

Dimensions:
mm
(inches)

3.5.2 IXD2012N SOIC(N)-8 Package Tape and Reel

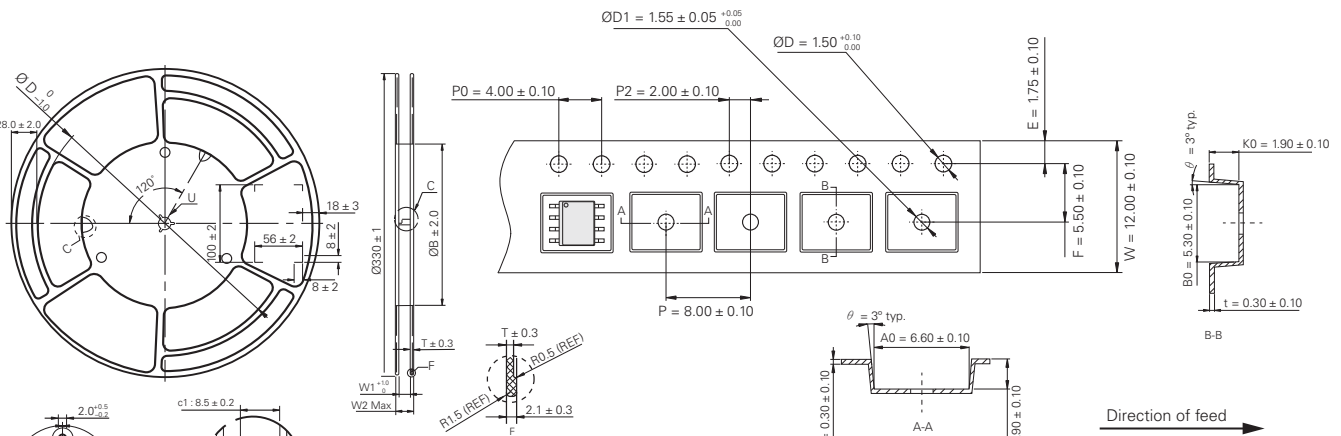

NOTES:

- (1) Measured from centreline of sprocket hole to centreline of pocket.
- (2) Cumulative tolerance of 10 sprocket holes is ±0.20.
- (3) Measured from centreline of sprocket hole to centreline of pocket.
- (4) Other material available.
- (5) Dimension with () is used for design reference purposes, NO measurement required.

Disclaimer Notice - Information furnished is believed to be accurate and reliable. However, users should independently evaluate the suitability of and test each product selected for their own applications. Littelfuse products are not designed for, and may not be used in, all applications. Read complete Disclaimer Notice at <https://www.littelfuse.com/disclaimer-electronics>