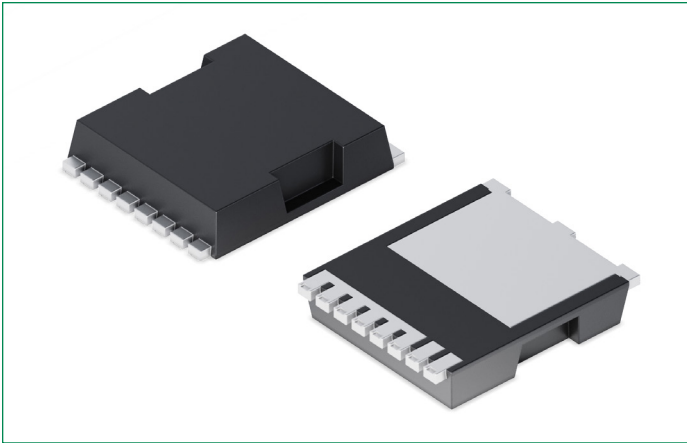
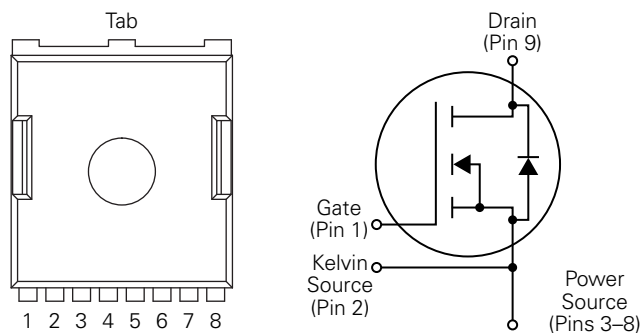

IXSG60N65L2K

650 V, 40 mΩ, 60 A SiC MOSFET

RoHS

HF

**Pinout Diagram (TOLL)****G:** Gate; **KS:** Kelvin Source; **S:** Power Source; **Tab:** Drain**Features**

- High blocking voltage with low on-state resistance
- High-speed switching with low capacitance
- High operating junction temperature capability
- Very fast intrinsic body diode
- Kelvin source contact
- MSL1 rated

Applications

- EV charging infrastructure
- Induction heating
- Motor drivers
- Solar inverters
- Switch mode power supplies
- Energy storage system

Product Summary

Characteristic	Value	Unit
V_{DSS}	650	V
$R_{DS(on)}$	40	mΩ
$I_D @ 25\text{ °C}$	60	A

Maximum Ratings ($T_c = 25\text{ }^\circ\text{C}$ unless otherwise specified)

Symbol	Characteristic	Conditions	Value	Unit
V_{DSS}	Drain-source voltage	$V_{GS} = 0\text{ V}, I_D = 100\text{ }\mu\text{A}$	650	V
V_{GSM}	Maximum gate-source voltage	Static (DC)	-5 to +20	V
	Transient gate-source voltage	Duty cycle < 1%, and pluse width < 200 ns	-10 to +23	V
I_D	Drain current (continuous) Fig. 21	$V_{GS} = 18\text{ V}, T_c = 25\text{ }^\circ\text{C}$	60	A
		$V_{GS} = 18\text{ V}, T_c = 100\text{ }^\circ\text{C}$	43	A
I_{DM}	Peak drain current Fig. 24	Pulse width limited by SOA and thermal impedance Z_{th}	150	A
P_{tot}	Total power dissipation Fig. 22	$T_c = 25\text{ }^\circ\text{C}$	249	W
T_{vj}	Virtual junction temperature range	-	-55 to +175	$^\circ\text{C}$
T_{stg}	Storage temperature range	-	-55 to +175	$^\circ\text{C}$
T_{sold}	Soldering temperature	-	260	$^\circ\text{C}$

Recommended Values

Symbol	Characteristic	Value			Unit
		Min.	Typ.	Max.	
V_{GSon}	Recommended turn-on voltage	15	-	18	V
V_{GSoff}	Recommended turn-off voltage	-5	-3.5	-2	

Thermal Characteristics

Symbol	Characteristic	Value			Unit
		Min.	Typ.	Max.	
$R_{th(j-c)}$	Thermal resistance from junction to case Fig. 23	-	0.6	-	K/W

Electrical Characteristics – Static ($T_c = 25\text{ }^\circ\text{C}$ unless otherwise specified)

Symbol	Characteristic	Conditions	Value			Unit
			Min.	Typ.	Max.	
I_{DSS}	Drain-source leakage current	$V_{DS} = 650\text{ V}, V_{GS} = 0\text{ V}$	-	3	100	μA
I_{GSS}	Gate leakage current	$V_{DS} = 0\text{ V}, V_{GS} = -5 \sim 20\text{ V}$	-	-	± 100	nA
$V_{GS(th)}$	Gate threshold voltage Fig. 8, 9	$V_{GS} = V_{DS}, I_D = 7.5\text{ mA}$	1.8	2.8	4.5	V
		$V_{GS} = V_{DS}, I_D = 7.5\text{ mA}, T_{vj} = 175\text{ }^\circ\text{C}$	-	2.1	-	
$R_{DS(on)}$	Drain-source on-state resistance Fig. 4, 5, 6, 7	$V_{GS} = 18\text{ V}, I_D = 20\text{ A} @ T_{vj} = 25\text{ }^\circ\text{C}$	-	40	53	m Ω
		$V_{GS} = 18\text{ V}, I_D = 20\text{ A} @ T_{vj} = 175\text{ }^\circ\text{C}$	-	60	-	

Electrical Characteristics – Dynamic ($T_{vj} = 25\text{ }^{\circ}\text{C}$ unless otherwise specified)

Symbol	Characteristic	Conditions	Value			Unit	
			Min.	Typ.	Max.		
C_{iss}	Input capacitance Fig. 16	$V_{DS} = 600\text{ V}, V_{GS} = 0\text{ V},$ $f = 1\text{ MHz}, V_{AC} = 25\text{ mV}$	–	2000	–	pF	
C_{oss}	Output capacitance Fig. 16		–	158	–		
C_{rss}	Reverse transfer capacitance Fig. 16		–	11.4	–		
E_{oss}	C_{oss} stored energy Fig. 17		–	31	–		μJ
Q_G	Total gate charge Fig. 18	$V_{DS} = 400\text{ V}, I_D = 20\text{ A},$ $V_{GS} = -3\text{ to }+18\text{ V}$	–	94.7	–	nC	
Q_{GS}	Gate-source charge Fig. 18		–	24.5	–		
Q_{GD}	Gate-drain charge Fig. 18		–	47.3	–		
$R_{g(int)}$	Gate input resistance	$f = 1\text{ MHz}$	–	2.9	–	Ω	
E_{on}	Turn-on switching energy Fig. 19, 20	$V_{DS} = 400\text{ V}, I_D = 30\text{ A},$ $V_{GS} = -3.5\text{ to }+18\text{ V},$ $R_{G(ext)} = 3.3\text{ }\Omega, L = 200\text{ }\mu\text{H}$	$T_{vj} = 25\text{ }^{\circ}\text{C}$	–	133.4	–	μJ
E_{off}	Turn-off switching energy Fig. 19, 20		$T_{vj} = 25\text{ }^{\circ}\text{C}$	–	37.6	–	
$t_{d(on)}$	Turn-on delay time Fig. 19, 20		$T_{vj} = 25\text{ }^{\circ}\text{C}$	–	7	–	ns
t_r	Rise time Fig. 19, 20		$T_{vj} = 25\text{ }^{\circ}\text{C}$	–	14.1	–	
$t_{d(off)}$	Turn-off delay time Fig. 19, 20		$T_{vj} = 25\text{ }^{\circ}\text{C}$	–	17	–	
t_f	Fall time Fig. 19, 20		$T_{vj} = 25\text{ }^{\circ}\text{C}$	–	8	–	

Reverse Diode Characteristics ($T_{vj} = 25\text{ }^{\circ}\text{C}$ unless otherwise specified)

Symbol	Characteristic	Conditions	Value			Unit
			Min.	Typ.	Max.	
V_{SD}	Diode forward voltage Fig. 10, 11, 12	$I_{SD} = 20\text{ A}, V_{GS} = 0\text{ V}$	–	4.1	–	V
		$I_{SD} = 20\text{ A}, V_{GS} = 0\text{ V}, T_{vj} = 175\text{ }^{\circ}\text{C}$	–	3.8	–	V
t_{rr}	Reverse recovery time	$V_{GS} = -3.5\text{ V}/+18\text{ V}, I_{SD} = 30\text{ A}, V_R = 400\text{ V},$ $R_{G(ext)} = 15\text{ }\Omega, L = 200\text{ }\mu\text{H}, di/dt = 3000\text{ A}/\mu\text{s}$	–	33.3	–	ns
Q_{rr}	Reverse recovery charge		–	192.1	–	nC
I_{rrm}	Peak reverse recovery current		–	17.5	–	A

Characteristic Curves

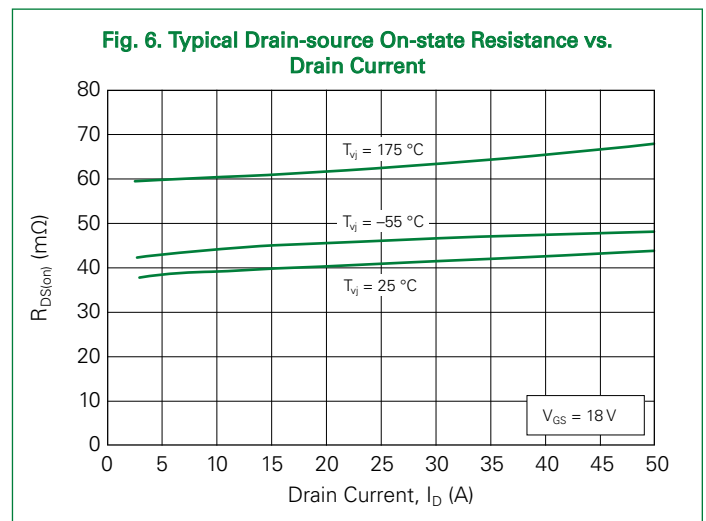
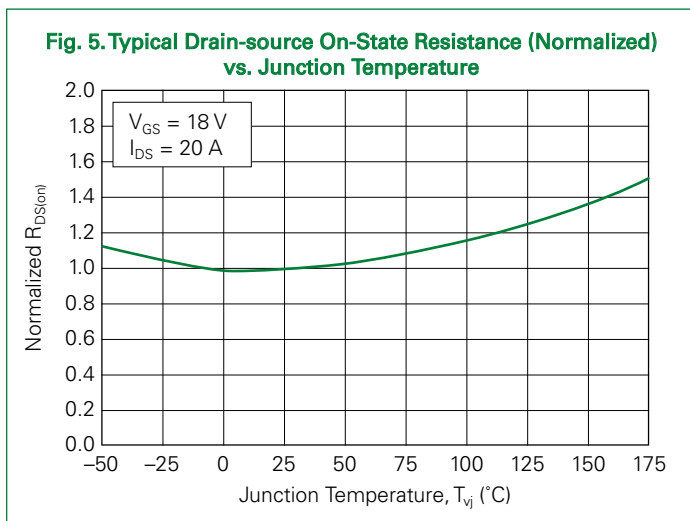
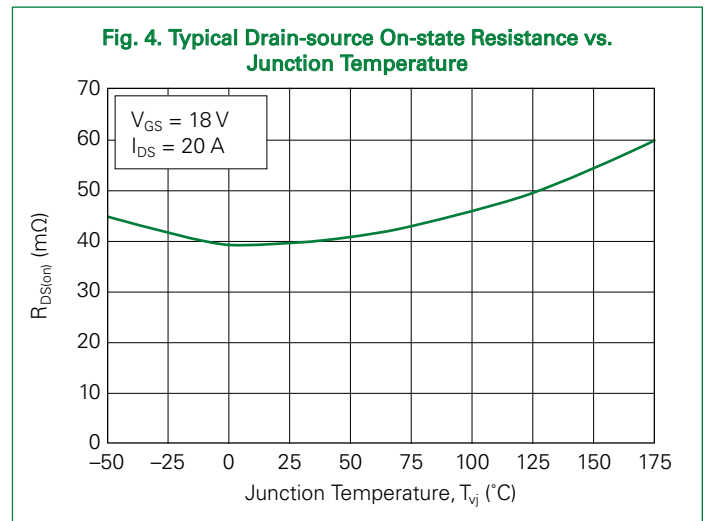
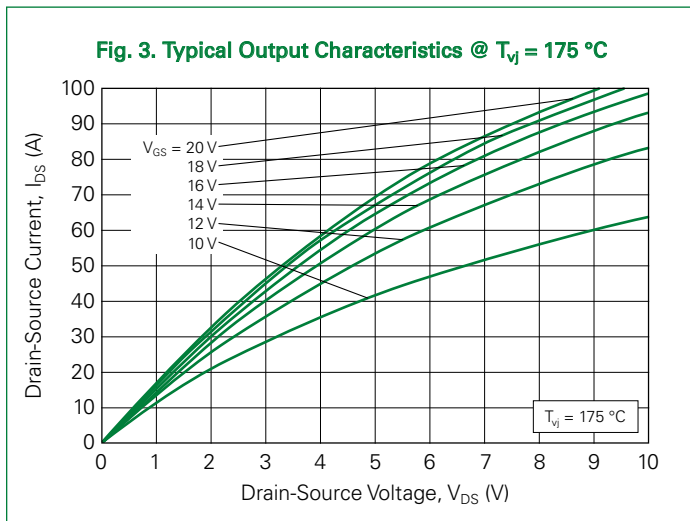
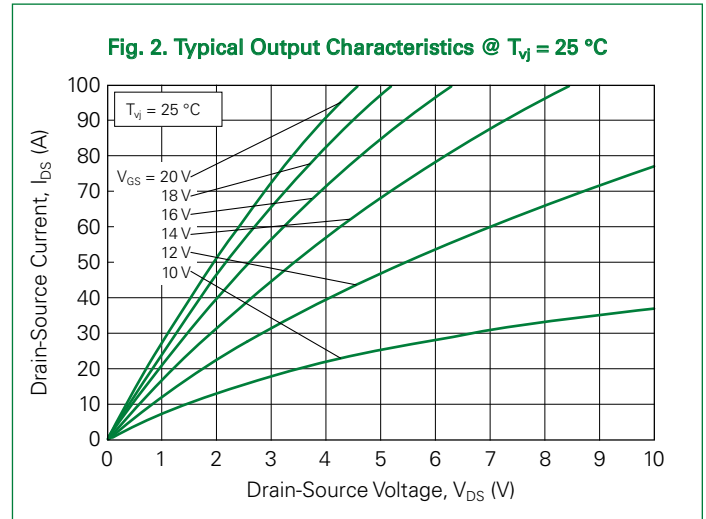
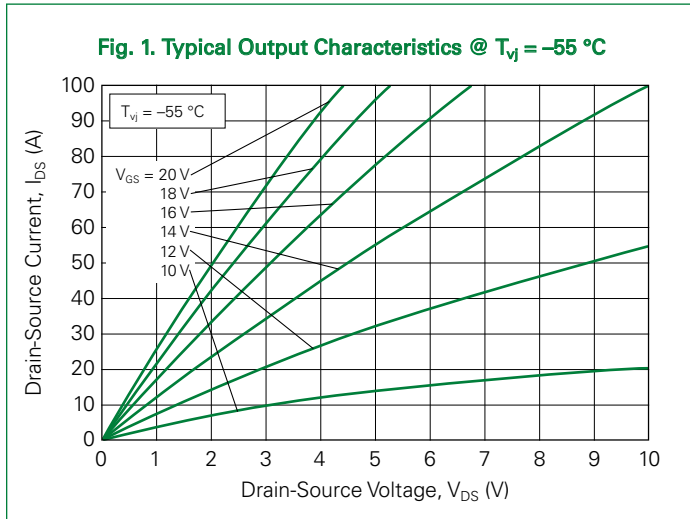

Fig. 7. $R_{DS(on)}$ vs. Temperature

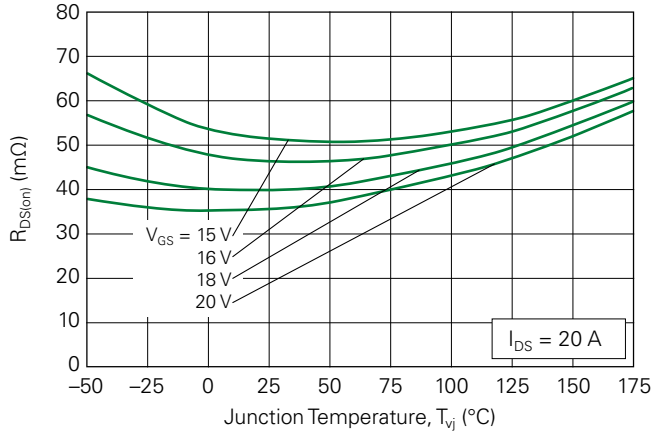

Fig. 8. Transfer Curves

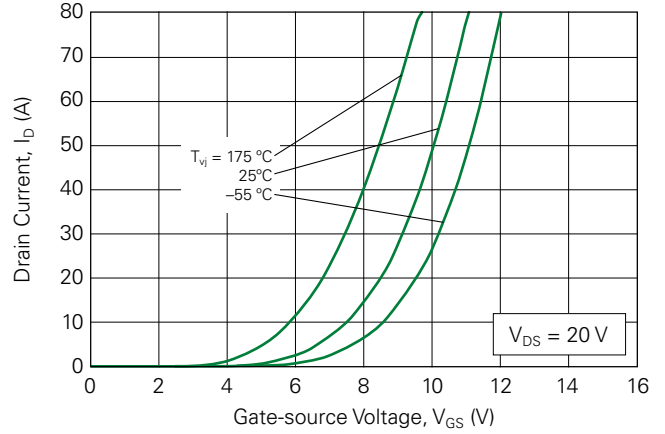

Fig. 9. Threshold Voltage vs. Temperature

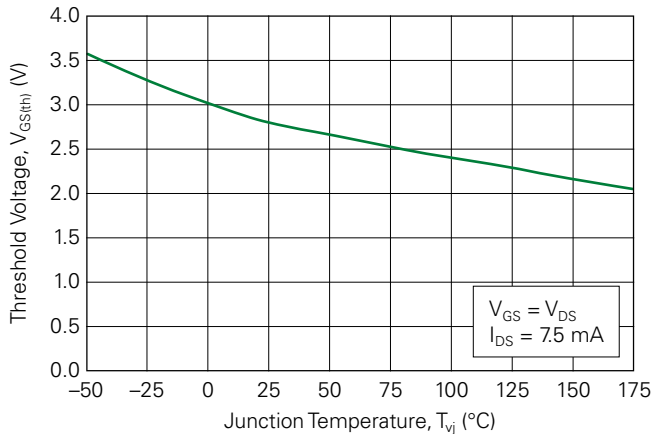

Fig. 10. Body Diode Curves @ $T_{vj} = -55$ °C

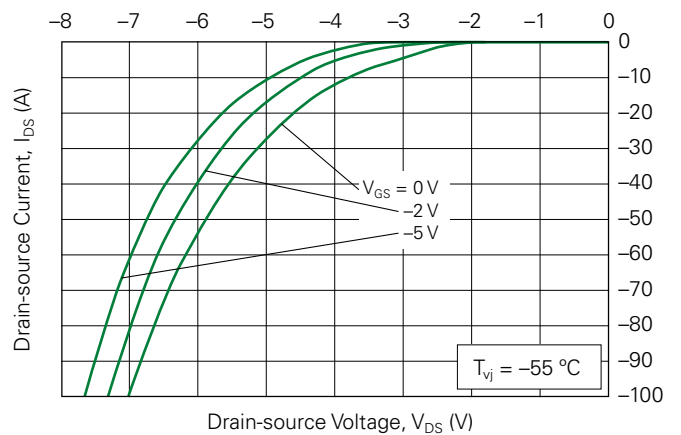

Fig. 11. Body Diode Curves @ $T_{vj} = 25$ °C

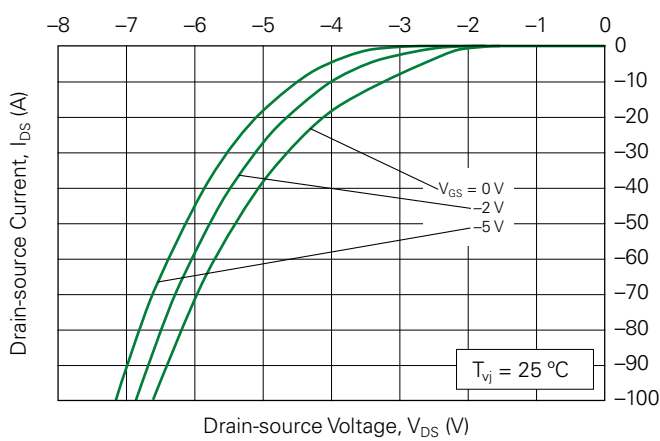

Fig. 12. Body Diode Curves @ $T_{vj} = 175$ °C

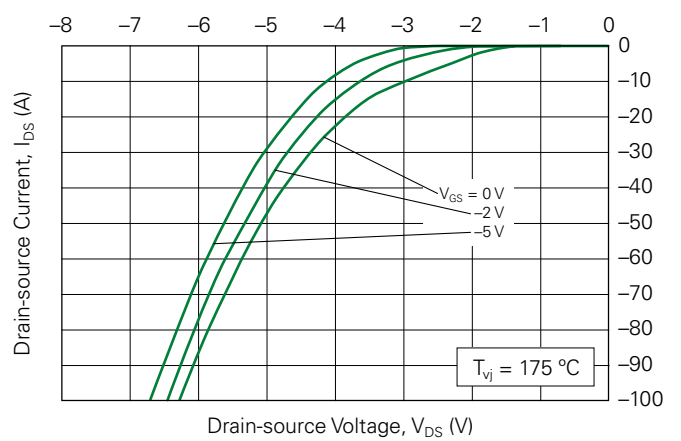

Fig. 13. Typical Reverse Conduction Characteristics @ $T_{vj} = -55\text{ }^\circ\text{C}$

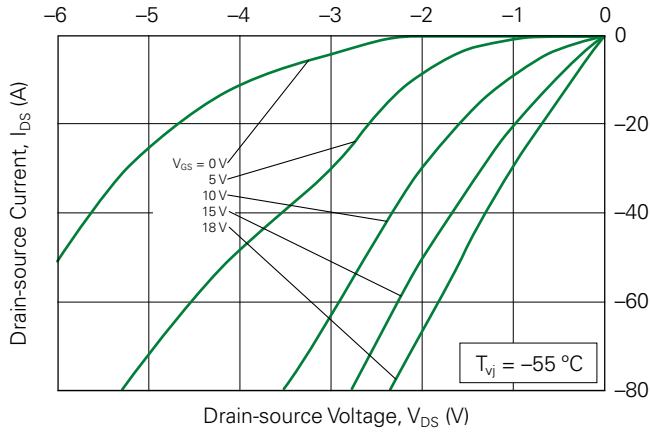

Fig. 14. Typical Reverse Conduction Characteristics @ $T_{vj} = 25\text{ }^\circ\text{C}$

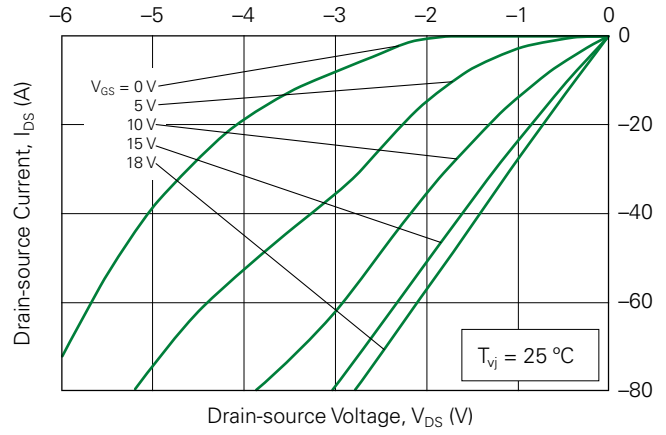

Fig. 15. Typical Reverse Conduction Characteristics @ $T_{vj} = 175\text{ }^\circ\text{C}$

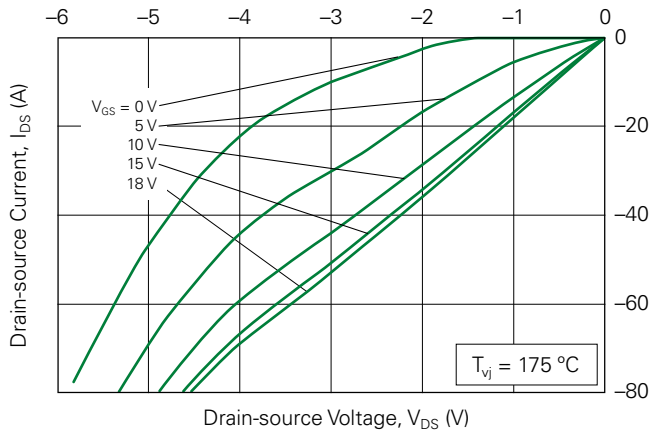

Fig. 16. Capacitance vs. V_{DS}

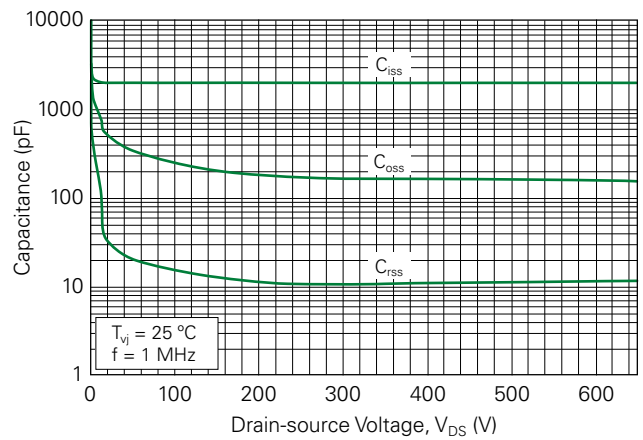

Fig. 17. Output Capacitor Stored Energy

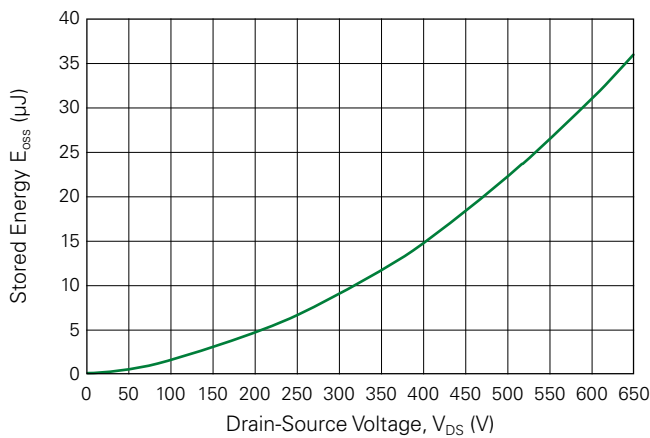

Fig. 18. Gate Charge Characteristics

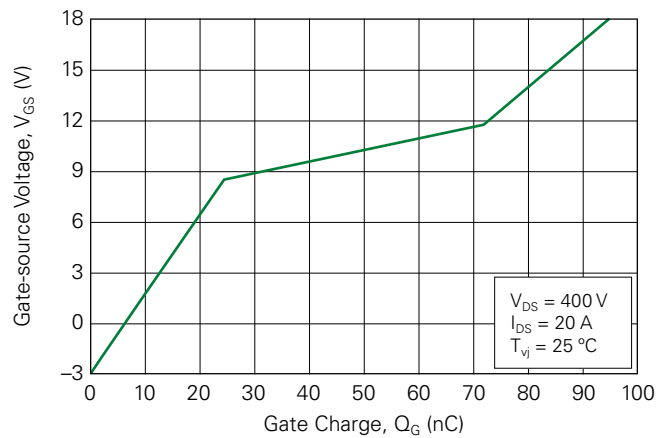

Fig. 19. Switching Energy vs. $R_{G(ext)}$

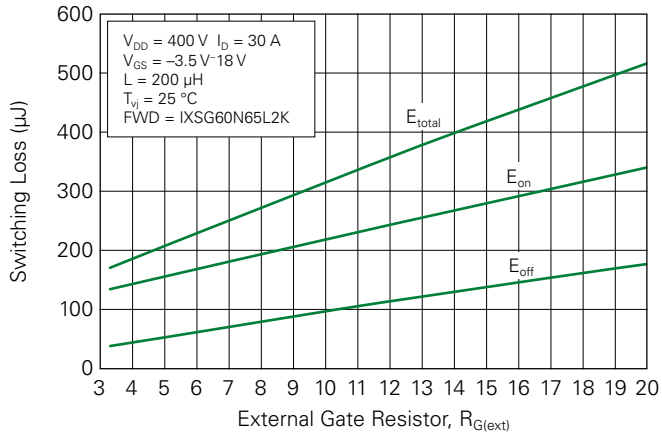

Fig. 20. Switching Times vs. $R_{G(ext)}$

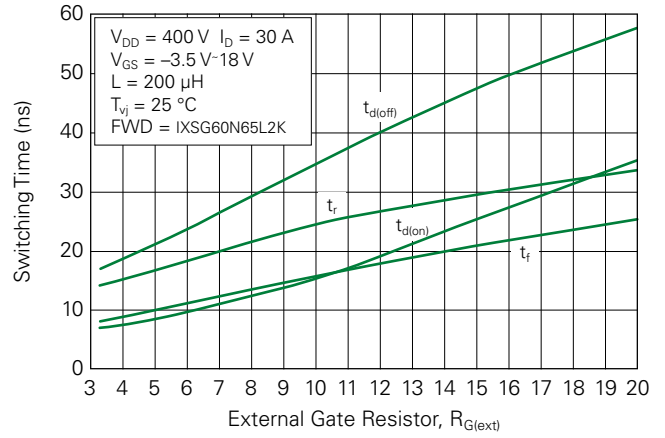

Fig. 21. Continuous Drain Current vs. Case Temperature

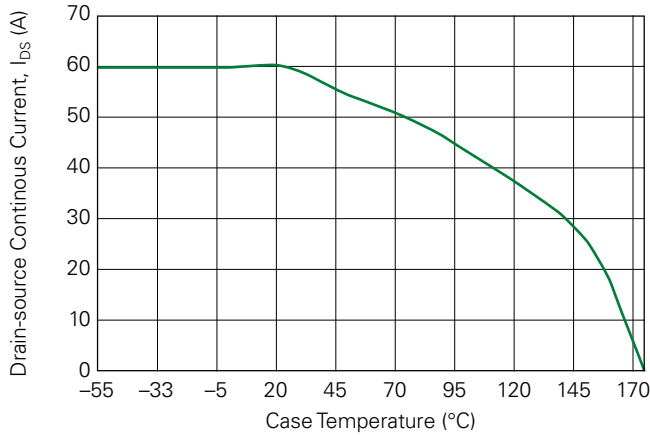

Fig. 22. Max. Power Dissipation Derating vs. Case Temperature

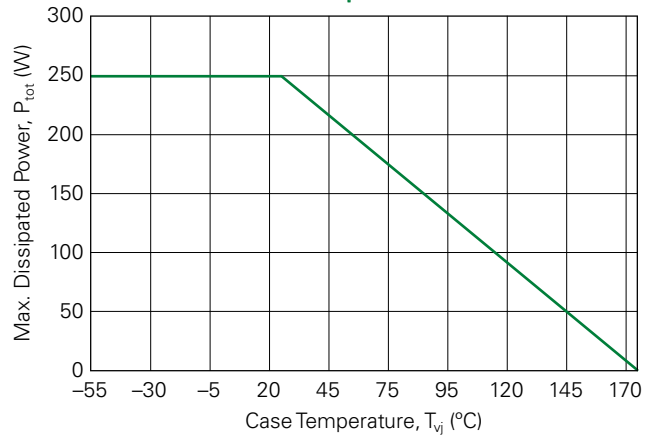

Fig. 23. Thermal Impedance

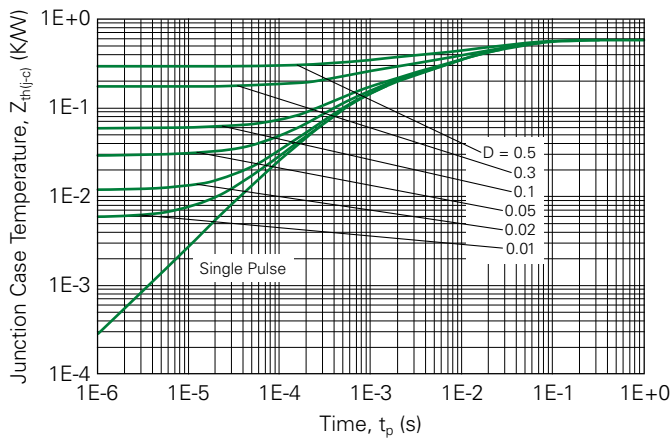
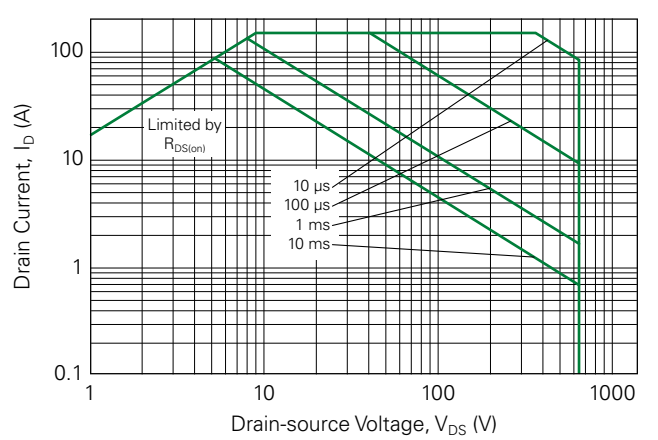
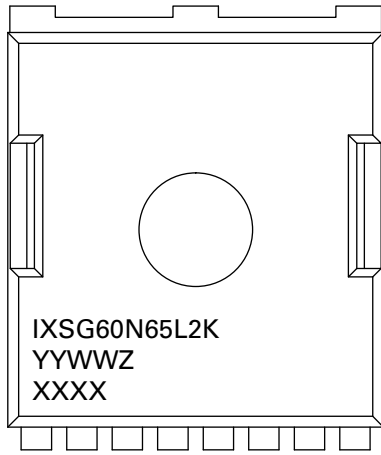

Fig. 24. Safe Operating Area



Part Number and Marking



IXSG60N65L2K = Specific Device Code
YY = Year
WW = Work Week
Z = Assembly Location
XXXX = Lot Traceability

Part Outline Drawing (TOLL)

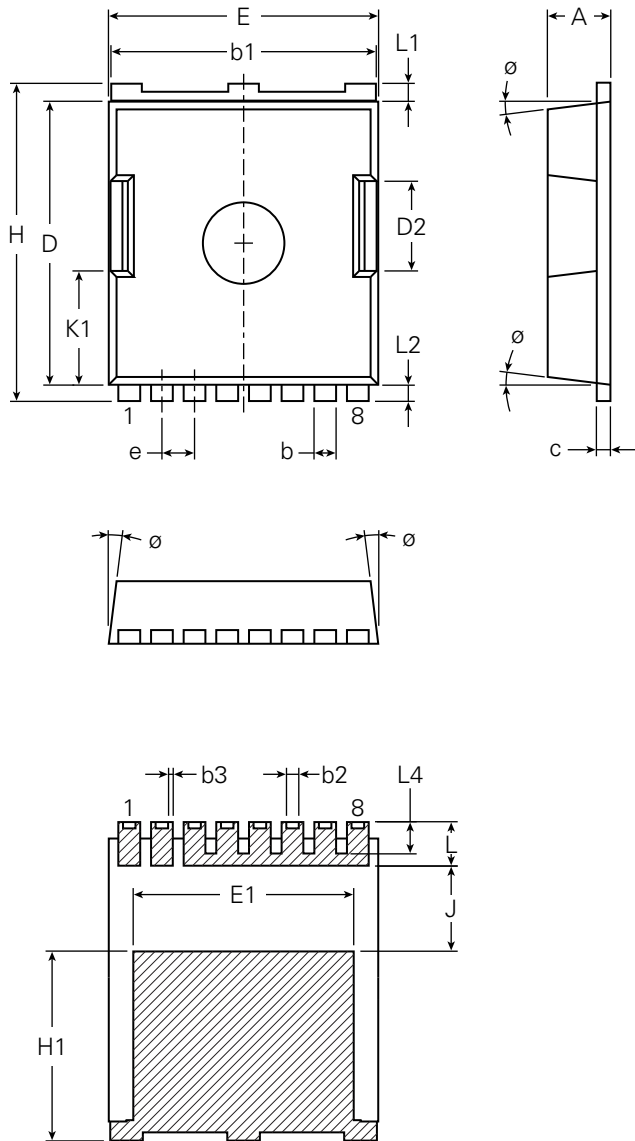

Symbol	Inches			Millimeters		
	Min.	Typical	Max.	Min.	Typical	Max
A	0.087	–	0.094	2.20	–	2.40
b	0.028	–	0.035	0.70	–	0.90
b1	0.382	–	0.390	9.70	–	9.90
b2	0.017	–	0.020	0.42	–	0.50
b3	0.003	0.007	0.011	0.07	0.17	0.27
c	0.016	–	0.024	0.40	–	0.60
D	0.405	–	0.417	10.28	–	10.58
D2	0.122	0.130	0.138	3.10	3.30	3.50
E	0.382	0.390	0.398	9.70	9.90	10.10
E1	0.311	0.319	0.327	7.90	8.10	8.30
e	0.047 BSC			1.20 BSC		
H	0.452	0.460	0.468	11.48	11.68	11.88
H1	0.266	0.274	0.281	6.75	6.95	7.15
J	0.118	0.124	0.130	3.00	3.15	3.30
K1	0.157	0.165	0.172	3.98	4.18	4.38
L	0.055	0.063	0.071	1.40	1.60	1.80
L1	0.024	0.028	0.031	0.60	0.70	0.80
L2	0.020	0.024	0.028	0.50	0.60	0.70
L4	0.039	0.045	0.051	1.00	1.15	1.30
∅	4°	7°	10°	4°	7°	10°

Disclaimer Notice

Information furnished is believed to be accurate and reliable. However, users should independently evaluate the suitability of and test each product selected for their own applications. Littelfuse products are not designed for, and may not be used in, all applications. Read complete Disclaimer Notice at <http://www.littelfuse.com/disclaimer-electronics>.



Part of:

