



Objectives

The work presented in this white paper outlines power electronic details on electrification of heavy-duty vehicles to contribute to reducing emissions in traffic by considering a value chain that consists of energy generation, storage, transportation, and consumption, as summarized in Figure 1.

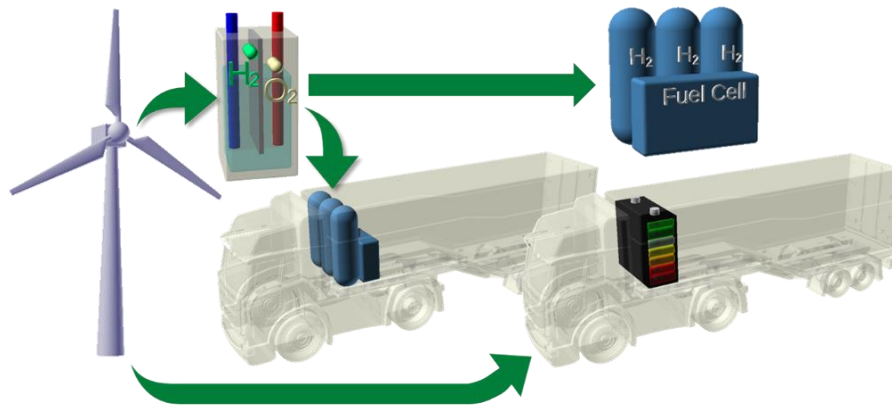

Figure 1. Electric Transportation Based on Clean, Renewable Energies

Target Audience

This document is intended for persons interested in electric heavy-duty vehicles such as buses and trucks, along with those wanting to get an insight into the infrastructure necessary to keep goods and people moving.

Contact Information

For more information on this topic, contact the Littelfuse Power Semiconductor team of product and applications experts:

- North America – NA_PowerSemi_Tech@Littelfuse.com
- Central & South America – CSA_PowerSemi_Tech@Littelfuse.com
- Europe, Middle East, & Africa – EMEA_PowerSemi_Tech@Littelfuse.com
- Asia, Australia, & Pacific Islands – APAC_PowerSemi_Tech@Littelfuse.com

Table of Contents

1. Introduction	3
2. The Value Chain in Electrified Transportation	4
3. Energy Storage	5
4. The Vehicle and it's Drive Train	5
5. Use-case I – Fleet Operation and Depot-Charging	9
6. Use-Case II – Opportunity Charging	12
6.1. Opportunity Charging by Pantograph	12
6.2. Opportunity Charging using Wireless Power Transfer (WPT)	13
7. Use-Case III – Individual Long-Haul Operation	15
7.1. Scaling Up Stacked Subassemblies	16
8. Use Case IV – Construction Machines	17
9. Conclusion	19
10. References	19

List of Figures

Figure 1. Electric Transportation Based on Clean, Renewable Energies	1
Figure 2. Overview of the 'Heavy-Duty Vehicle' Application	3
Figure 3. Littelfuse Power Semiconductors from Energy Generation to Consumption	4
Figure 4. Simplified Block Diagram of a Battery Electric Vehicle	5
Figure 5. Typical Power Section of an Electric Vehicle's Drive Train	6
Figure 6. Block Diagram of a Fuel-cell-based Electric Vehicle's Drive Train	6
Figure 7. Fuel-cell-based Energy Conversion System	7
Figure 8. Rectifier Topology with B12C, also noted as B6C-2P	8
Figure 9. Modern Bus-Depot with Charging Infrastructure	9
Figure 10. Charging Electric Delivery Vehicles, St. Pancras Station, London 1917	9
Figure 11. Bidirectional Charger Schematic and Suitable Components	10
Figure 12. Holistic Approach for Fleet Operation using Solar Power and Energy Storage	11
Figure 13. Top-down Pantograph for Opportunity Charging	12
Figure 14. General Appearance of a High-power Inductive Charging System	13
Figure 15. Generic Structure of a WPT-System	13
Figure 16. Series-compensated, Resonant WPT Setup	14
Figure 17: Comparing the Operating Area of High-power Passenger Car and Commercial Vehicle Chargers	15
Figure 18. Structure of a MW-scale DC-Charger	16
Figure 19. MW DC-Charger Based on Thyristor Bridges	16
Figure 20. Power Section to Control a Switched Reluctance Motor (SRM) and a Schematical View to the Machine	17
Figure 21. High-power Drive Train in Mobile MW Applications	18

1. Introduction

Trucks, buses, and construction vehicles, also referred to as heavy-duty vehicles, are estimated to contribute 25% of the emissions in traffic and about 6% of Europe's overall greenhouse gases^[1].

Due to the growth in online business activity, a corresponding growth in long-haul operations across continents and an increase in in-city delivery activities can be observed. This is not limited to the European Union at all. Based on numbers published by the US-Bureau of Transportation^[2], trucks in the US travel about 296 billion kilometers every year, burning 113 billion liters of gasoline and in turn, producing as much as 294 million metric tons of carbon dioxide.

Driven by legislation and more restrictive requirements regarding emissions, fleet operators are increasingly switching to zero-emission vehicles. Enhancing public transportation to reduce the number of individual cars in all major cities around the globe is considered as another cornerstone of reducing emissions in the metropolises. Here too, operating zero-emission vehicles is the targeted option, best combined with green, renewable energies.

Electrifying vehicles in the class exceeding 3.5 tons is a multidisciplinary task and a particular challenge for power semiconductors. Compared to a typical passenger car, designed for about 8000 operating hours, a truck or bus is built for a massively longer lifetime – both service life and operating uptime. The common requirement targets 8 to 10 hours of operation, 360 days a year. With up to 400 km predicted travel per day, this sums up to exceed 2 million kilometers in 15 years of service. In this respect, buses used in urban transportation are no less challenging, as a single day also requires covering 200-300 km but the permanent start-stop-mode of operation inherently brings up further challenges.

An all-electric heavy-duty-vehicle contains a multitude of subsystems that demand reliable solutions. With a focus on power electronic components, Figure 2 gives an insight into what is included.

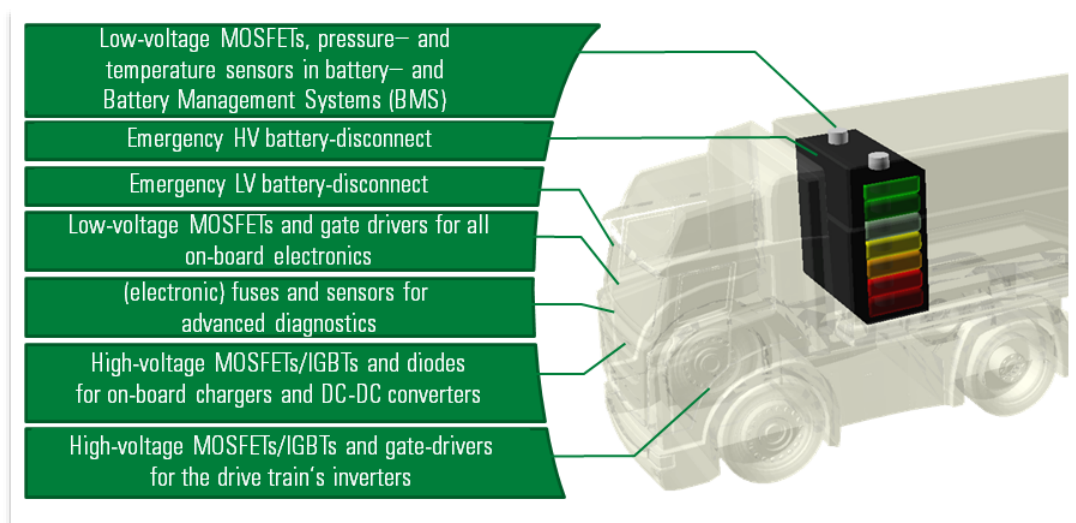

Figure 2. **Overview of the 'Heavy-Duty Vehicle' Application**

The development that batteries have gone through in the last decade now makes them a viable solution, even for electric heavy-duty vehicles. The price per kilowatt hour has dropped by about 88% in the last decade^[3]. Further decline is expected due to new materials and production processes along with increased manufacturing capacities. At the same time, the energy density grew continuously and here too, news about technological breakthroughs is reported frequently.

As a final parameter, the number of charging cycles a battery can support becomes important as it reflects the service lifetime of the batteries. From the few hundred cycles a former lead-gel technology provided, modern lithium-ion batteries now achieve several thousand cycles. Manufacturers around the globe are working on further improvements and technologies are already announced that achieve more than 10,000 cycles and energy densities up to 1 kWh/kg^[4].

All of this contributes to making batteries more and more attractive, even for long-distance operations. What remains is the challenge of charging the vehicles in a reasonable time. What can be considered *reasonable* massively depends on the vehicle's use case.

For buses operated for local passenger transport, the most common option is charging in a depot during a break between shifts or overnight. Here, reasonable refers to a period of several hours when the bus is idle in the depot. Optionally, charging at dedicated stops becomes an option. With only minutes of time available, charging power needs to be higher to inject enough energy into the batteries. As several stations could feature charging, a combination with depot-charging can be considered.

For trucks used in logistics operations, a pause of several hours for charging cannot be tolerated. In this case, charging must be done during the break, which the driver has to observe anyway due to legal requirements. Future autonomous trucks without a driver would not even require a recreational break and recharging in the shortest time technically possible will become desirable.

As such, infrastructure to support operating this class of vehicles needs to be considered a part of the value chain as well.

2. The Value Chain in Electrified Transportation

From power generation in renewable energy systems to electrolysis, drive trains, chargers, and smaller on-board applications, designs in a power range from a few watts to a few megawatts can be found along the transportation value chain. The interconnected parts are pictured in Figure 3.



Figure 3. Littelfuse Power Semiconductors from Energy Generation to Consumption

The common ground for all of them is the need for highly efficient, reliable electronic subsystems. Within this demanding environment, controls, protection, sensors, and power electronics are the omnipresent components to handle the energy transfer safely and efficiently. As depicted, Littelfuse products are available to build, operate, and maintain this environment with reliable components.

3. Energy Storage

There are three major ways to store electric energy to power mobile applications and each of them has its pros and cons.

- 1) Direct storage of energy in an electric field is done in capacitors. Capacitors can be charged and discharged at very high rates, thus providing enormous power density. Additionally, capacitors do not suffer from being charged as much as batteries do and can easily achieve millions of charging cycles. The energy stored is defined by the capacitor's capacity and voltage allowed, according to $E_c = \frac{1}{2}C \cdot U^2$. Technologically, capacitors with high voltages only feature low capacities and vice versa. As the energy density, measured in kWh/dm³, is lower than in batteries, capacitors are combined with batteries to supply peak power, while the battery acts as major energy storage.
- 2) Chemically, energy is stored in batteries. The chemical processes involved are the limiting factor regarding the charge/discharge capability of a given battery chemistry. Modern Lithium-ion-battery cells can store up to 0.2-0.3 kWh per kilogram and are currently favored in most mobile applications. Regarding cyclic stability, chemistries currently employed achieve several thousand charge-discharge cycles.
- 3) Hydrogen as an energy carrier can be obtained from chemical processes and purified in the second step. Electrolysis to separate water into oxygen and hydrogen presents a way to use renewable energy sources to support the process. In a so-called fuel cell, hydrogen and oxygen react and create electricity in turn. Most of the hydrogen available today is extracted from oil or natural gas using steam reformers.

4. The Vehicle and its Drive Train

Regarding the block diagram pictured in Figure 4, the drive train in a heavy-duty vehicle technically isn't that different from the one used in an electric passenger car.

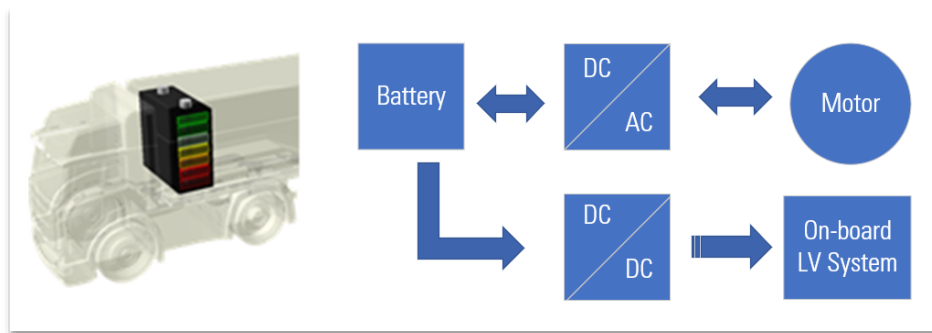

Figure 4. Simplified Block Diagram of a Battery Electric Vehicle

Two major differences compared to passenger cars arise from the application. The levels for continuous power output outgrow those of a passenger car. The same is true for the operating lifetime. Typically, while a passenger car is supposed to last 6000-8000 operating hours, trucks and buses are expected to survive ten times as much.

Still, the majority of electric motors in use in commercial vehicles are permanent magnet synchronous machines, governed by a 2-level inverter, as seen in Figure 5.

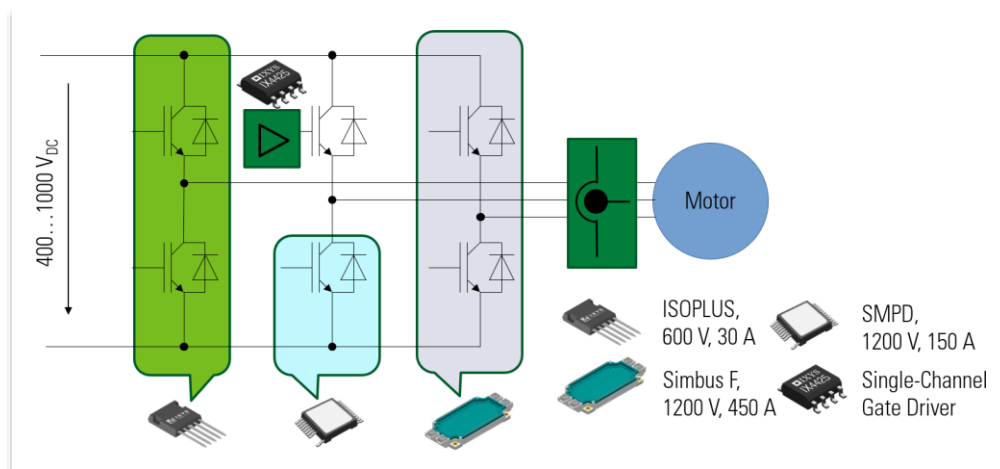

Figure 5. Typical Power Section of an Electric Vehicle's Drive Train

In the extended block diagram in Figure 6, a fuel-cell that converts hydrogen and oxygen into water, heat, and electricity is used as a power source. Here, large tanks contain the hydrogen. Batteries are still needed to provide peak power during acceleration and store energy during recuperation.

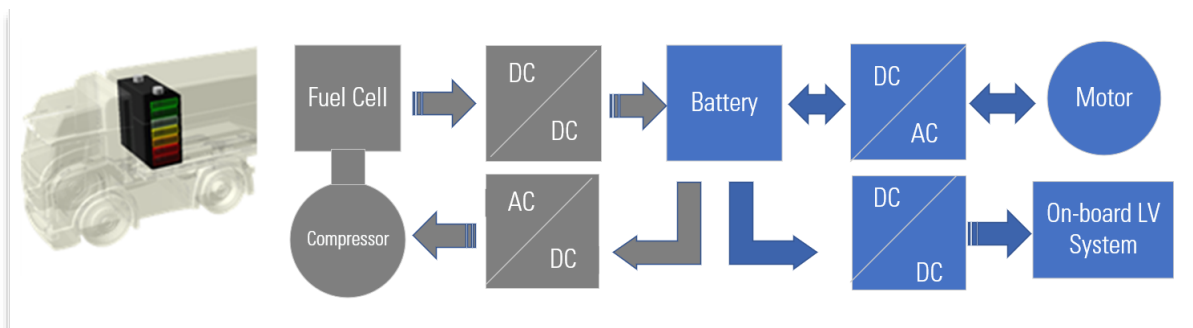

Figure 6. Block Diagram of a Fuel-cell-based Electric Vehicle's Drive Train

In addition, further power electronic components are needed in a DC-DC converter that forms the interface between fuel-cell and battery.

An important and inherent part of the fuel-cell-based drive train is the compressor that drives an intense airstream into the fuel-cell. This air contains the oxygen necessary for a balance between hydrogen and oxygen.

A closer look into the details of the fuel-cell explains the challenges that come with the compressor. Figure 7 is a sketch of the parts involved in energy conversion using hydrogen.

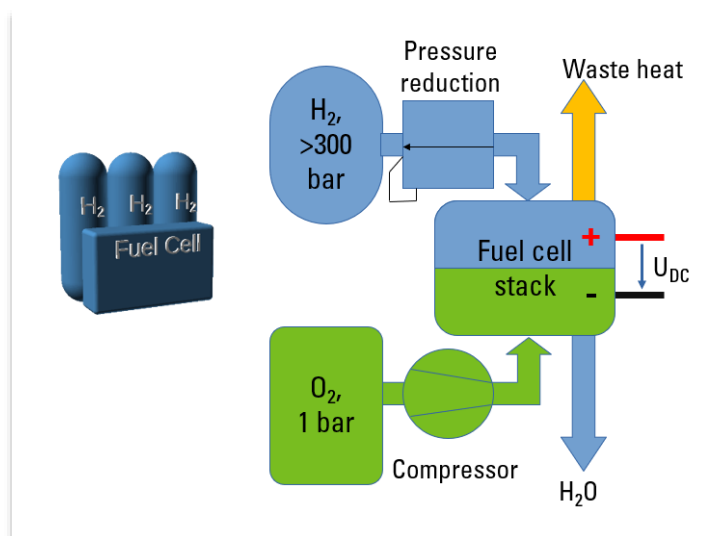

Figure 7. Fuel-cell-based Energy Conversion System

An estimation for the air stream necessary to achieve 150 kW continuous operation can be obtained from the balance of gases needed within the fuel cell:

- 1 kg H₂ and 8 kg O₂ generate about 20 kWh of electric energy
- 7.5 kg H₂ + 60 kg O₂ are needed per hour
- 1 m³ air is 1.2 kg in weight and contains 0.24 kg of oxygen

From this, 250 m³ atmospheric air per hour has to be supplied to the fuel-cell. As the load to the fuel-cell can change rather quickly, the compressor needs to feature rapid start-up capabilities, often leading to a requirement of accelerating from zero to 100% of speed in fractions of a second. Because of these requirements, the inverter to drive the compressor is often rated in a 20-40 kW regime.

To really consider fuel-cell-based vehicles a green technology, it is mandatory to create the hydrogen from renewable energies. Extracting it from oil or natural gas is technically an option but this so-called black hydrogen leads to a massive creation of carbon dioxide as a by-product.

Combining electricity from renewable sources like wind and solar power with electrolysis to separate water into hydrogen and oxygen is currently under consideration. Particularly if used to consume excess power, it provides an option to support grid stability and create hydrogen as a by-product. Various nations around the world have filed programs to integrate the use of hydrogen as a cornerstone to reduce greenhouse gas emissions.

Electrolysis is a DC-current-driven application. A single electrolysis cell features a forward voltage of less than 2 V but can demand a current throughput of several thousand amps in industrial hydrogen generation. The most widespread MW-scale rectification scheme is the B12C topology given in Figure 8.

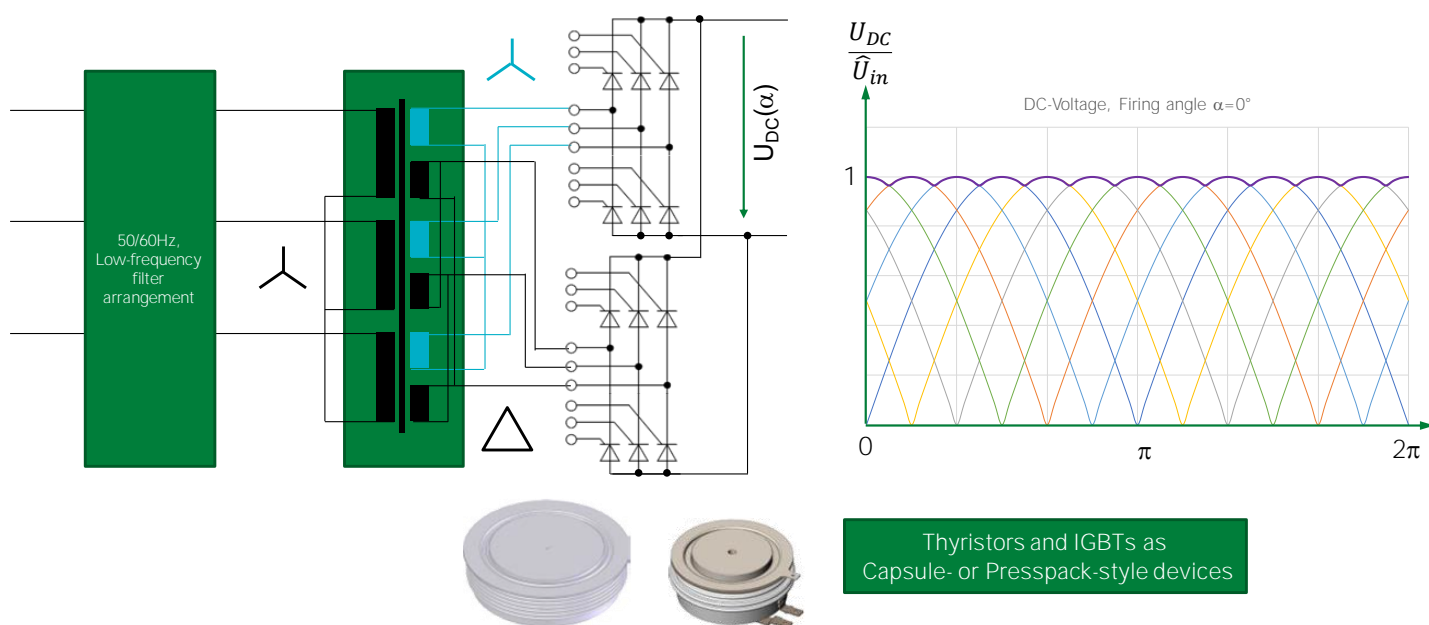

Figure 8. Rectifier Topology with B12C, also noted as B6C-2P

The twelve-pulse B12C topology, also considered a paralleling of two B6C and noted as B6C-2P, achieves a very low voltage ripple on the DC-side, even without smoothing and filtering. The single-stage AC-DC energy conversion also achieves outstanding efficiency.

Corresponding power electronic components in use are thyristors or IGBTs in presspack housings, typically mounted in so-called stacks. With current ratings up to 4500 A in IGBTs and even exceeding 8000 A for thyristors, these devices easily support the high current requirement. Additionally, the short-on-fail feature of presspacks leads to improvements in reliability and system availability.

5. Use-case I – Fleet Operation and Depot-Charging

Though modern technology in batteries and cutting-edge power semiconductor solutions enable the design of highly efficient infrastructure, the idea itself is not as new as many people think. Figure 9 depicts the modern version of depot-charging, while Figure 10 offers an insight into a time more than 100 years gone by.



Courtesy of EBUSCO

Figure 9. Modern Bus-Depot with Charging Infrastructure



Figure 10. Charging Electric Delivery Vehicles, St. Pancras Station, London 1917

Depot-charging is the preferred option for local fleet operation, particularly for buses and any kind of delivery vehicles. These are operated on rather fixed routes and are idle for a period of hours during night-time.

This method comes with a reduced need of charging power as well as with further options in energy-management. Including stationary batteries, decoupling the time of charging buses from times of having excess energy becomes an option.

As of 2021, common battery-electric buses feature battery capacities in the range of 250 to 500 kWh, enabling them to operate one shift without charging. A charger in a depot only needs to recharge one vehicle overnight. Even in the case of recharging 80% of 500 kWh in 6 hours, 70 kW of power is sufficient. Of course, for the whole depot, this is multiplied by the number of vehicles to be charged at the same time.

A typical schematic of a charger includes an input stage which is capable of adapting the DC-link-voltage, a stage for galvanic isolation, and an output rectifier, as seen in Figure 11.

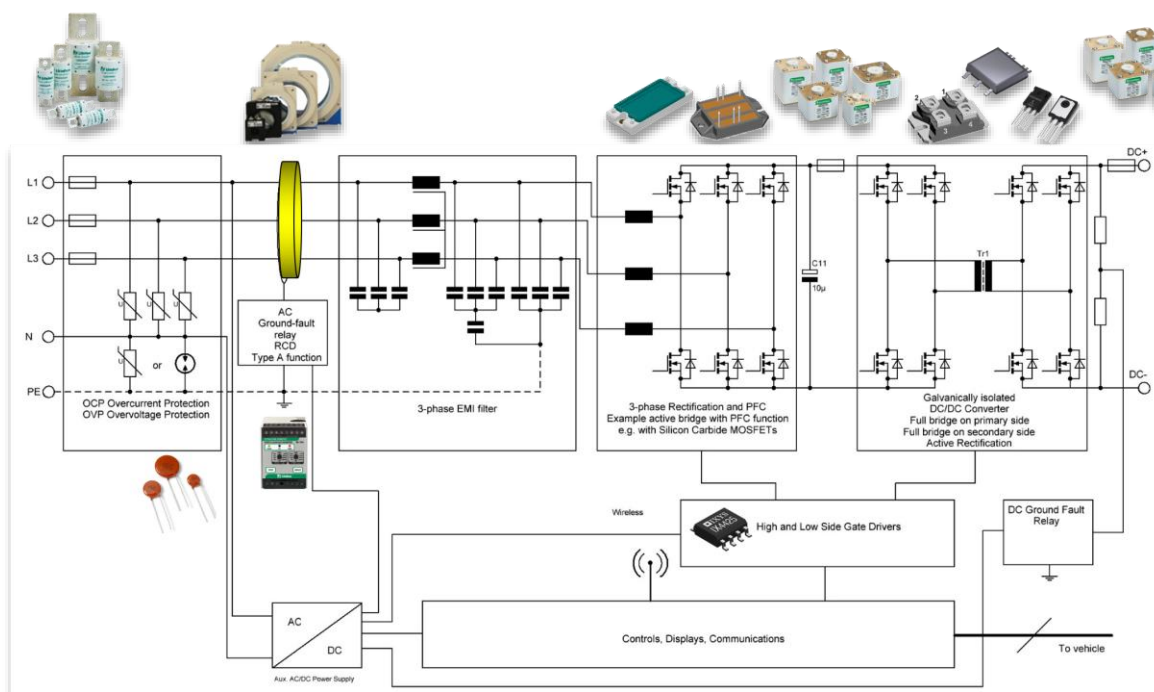

Figure 11. Bidirectional Charger Schematic and Suitable Components

Chargers are typically built in a modular approach from subsystems that can be stacked to increase the output power. Common designs feature 15-60 kW per subsystem and the choice of components varies with the output power requirement and cooling preferences. While units with forced-air-cooling in a range of 10 to 15 kW are widely built with discrete devices, units with higher power levels use liquid cooling and are mostly constructed from power modules. Besides an increase in output power, paralleling units can also be used as redundancy to enable system operation at lower power instead of losing the complete system in case of failure in a single module.

Depot-charging is also a door-opener for secondary grid services. Stationary energy storage helps reduce the load to the grid, and during high energy demand, even supports the grid. Load balancing and scheduled charging becomes an option too. Charging times can be aligned with periods of having excess energy with correlating low, or even negative, energy prices at night. Holistically, depots as well as larger industrial areas could become solar power stations. In a fleet of vehicles with a fixed schedule, not all of them have to be fully charged at the same instant. Sharing of energy between the vehicles is possible and those vehicles that are not scheduled to be in service can contribute their stored energy as well. A potential scenario can be seen in the rendered image in Figure 12.



Figure 12. Holistic Approach for Fleet Operation using Solar Power and Energy Storage

Initial projects like the one shown in Figure 12 are already built and in use^[6], with even more advanced projects currently under construction^[7].

Back in 2014, trials with electric buses in New York^[8] revealed that electric buses cut the cost per mile driven by more than 1 US\$ compared to their Diesel or CNG-powered counterparts.

A further unique situation arises in the United States. Here, more than 480,000 school buses are in service, recognized as being the nation's largest public transportation fleet. These buses are driven about 6 billion miles, or 9.6 billion kilometers, every year^[9]. Typically, they operate a run in the morning and a second one in the afternoon, not being driven in the time in between. Assuming 200 kWh per electrified bus^[5], this would resemble a decentralized energy storage with 96 GWh storage capacity. Especially during summer vacation, these buses are not in service for 100 consecutive days and could offer grid support exactly in times of high energy demand due to the increased use of air conditioning in summer.

The current US administration, as of mid-2021, already announced a zero-emission policy for this particular vehicle fleet.

6. Use-Case II – Opportunity Charging

Operating a fleet of vehicles along predefined routes opens the option to extend the driving range by adding smaller amounts of energy more frequently. This is the so-called opportunity charging which works best if it takes place in a fully automated manner.

Two basic solutions are predestined for this way of charging.

6.1. Opportunity Charging by Pantograph

Pantographs are mechanical systems that allow large electric contacts to move over longer distances and safely contact their counterparts. Pantographs are widely used in tramways and railway applications and offer a proven reliable technology. Depending on the mounting position, pantographs can be separated into top-down and bottom-up systems. While bottom-up systems are mounted on the vehicle and contact the station, top-down-mechanics are part of the station, lowered down to the vehicle. Figure 13 gives an example of how charging by pantograph can be set up.



Figure 13. Top-down Pantograph for Opportunity Charging

Construction of the infrastructure remains restricted to the roadside. Therefore, such an installation can be built as an upgrade to existing stations in the event a suitable power supply is available locally. As this is rarely the case, buffering the station by battery storage is a widely appreciated solution to decouple high-power charging of the vehicle from recharging the stationary batteries.

In comparison to depot-charging, opportunity charging demands higher power levels due to the limited time to stop at a single station. It is common to apply power levels of 125-250 kW. Charging voltage and current are aligned between the station and the vehicle's battery management systems before the charging process is started. Because of the high power involved, charging via pantograph is always DC charging with direct access to the vehicle's battery.

For future installations, pantographs are foreseen as a predestined solution, especially for autonomous vehicles, as no plug or wire is involved that needs to be handled precisely. The systems can easily handle vehicles with different heights and can be constructed to tolerate misplacements between station and vehicle.

6.2. Opportunity Charging using Wireless Power Transfer (WPT)

Wireless charging, also popular for mobile devices like smartphones, can be upgraded in power to suit the needs of large-scale energy transfer. Wireless power transfer for vehicle-scale systems is described in SAE J2594. Figure 14 schematically outlines the general setup for a WPT-installation.

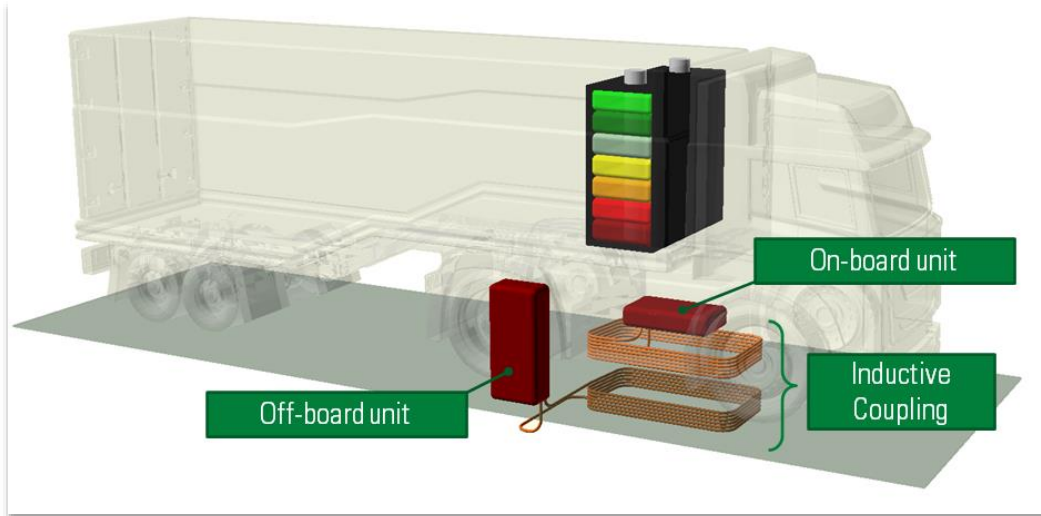

Figure 14. General Appearance of a High-power Inductive Charging System

WPT-systems inherently consist of two independent parts that exchange energy via magnetic flux. The typical conversion stages involved are included in Figure 15.

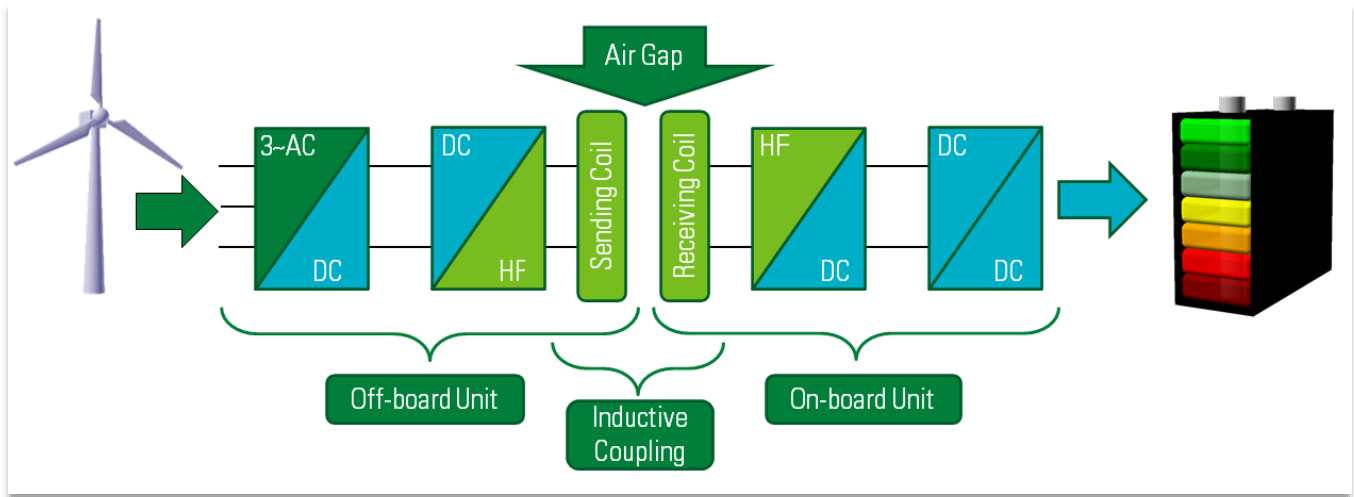

Figure 15. Generic Structure of a WPT-System

The wireless power transfer standard calls for interoperability between sending and receiving partners despite their differently rated power capabilities. This leads to the requirement that a sending equipment optimized for 7.7 kVA has to remain compatible with receivers for 3.3 kVA, 11.1 kVA or 22 kVA. It is obvious that sending and receiving coils have different geometries for different power classes while within a single class, sending and receiving coils can share the same geometry. A consequence of the interoperability-requirement, non-symmetric coil arrangements of receiving and sending coil have to be tolerated.

To prevent sacrificing too much of the transfer efficiency, SAE J2594 set a target for the transfer efficiency to reach 80% at least.

To fulfill this requirement, series-compensated resonant circuits, as drawn in Figure 16, became a common approach, operated in a frequency range of 80-140 kHz.

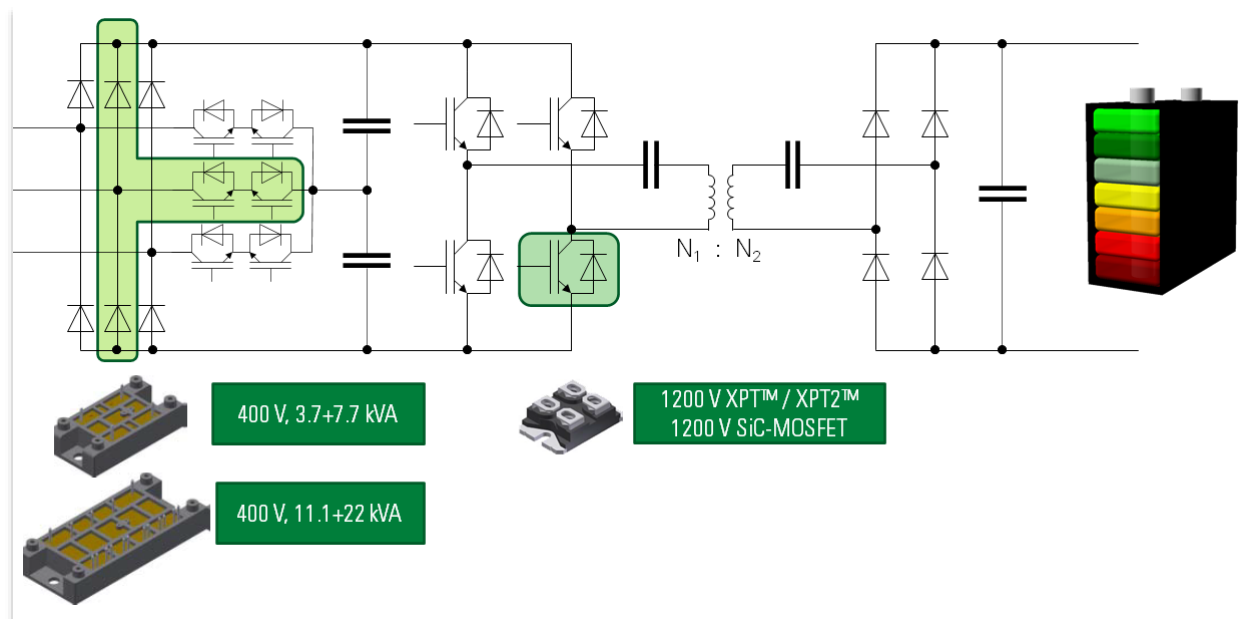

Figure 16. Series-compensated, Resonant WPT Setup

A multitude of input rectifier topologies can be considered, including static diode rectifiers as a cost-optimized solution or thyristor-based versions. Due to superior EMI behavior, reduced effort necessary for filtering, and adjustable DC-link-voltage, the Vienna Rectifier is an often-seen solution.

With a high switching frequency of 80-140 kHz to drive the sending coil demanded by the standard, IGBTs with low switching losses or SiC-MOSFETs can be chosen for the DC-DC-conversion stage.

Inductive chargers need to be installed in a place where the vehicle can run over it. In contrast to pantographs, this has a more severe impact to the infrastructure, especially in public traffic. Therefore, inductive charging is a suitable solution mostly for semi-public areas. For example, baggage trolleys at airports can benefit from wireless power transfer as the power levels, energies involved, and topographic conditions suit the use-case.

Besides the technical challenge, wireless power transfer comes with a unique requirement. The gap between sending and receiving coils can be tens of centimeters, which is enough space to host foreign objects or even living objects. Care has to be taken that no conductive parts are present during the charging process as induced energy can lead to highly unwanted heating or even melting of metal objects. The same is true for living objects like pets and smaller animals. The magnetic field during charging can exceed the limits considered tolerable to living tissue and cause severe damage.

7. Use-Case III – Individual Long-Haul Operation

Traveling on random routes as in long-haul logistics requires similarly individual high-power charging. This high-power charging needs to become part of the existing infrastructure to allow for seamless integration of electric trucks into the mobility sector.

The 350 kW chargers currently rolled out for passenger cars in Europe would still need a 2-hour break for recharging the 500 to 600 kWh battery set of a larger truck. Up to 800 kW have already been announced but the CharIN organization involved in defining charging standards has introduced the standard on High Power Charging for Commercial Vehicles (HPCCV).

With a DC voltage up to 1500 V and a maximum charging current up to 3000 A, charging at rates exceeding 2 MW becomes possible. Figure 17 holds a comparison to visualize the scale of commercial vehicle charging vs. passenger car charging.

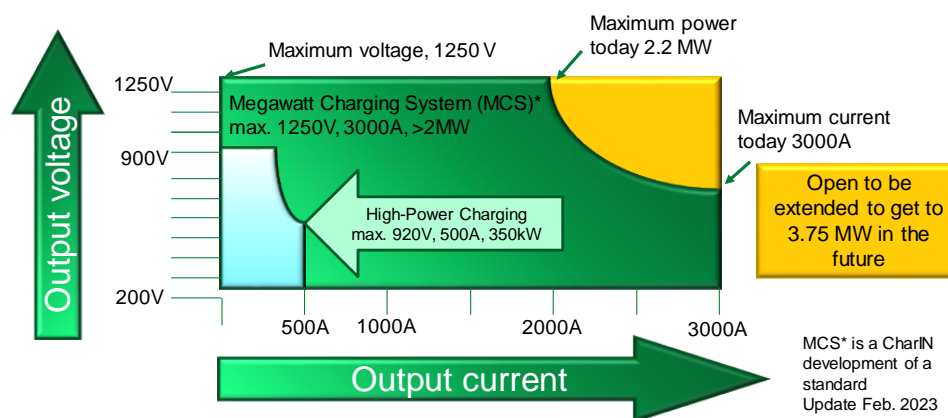

Figure 17: Comparing the Operating Area of High-power Passenger Car and Commercial Vehicle Chargers

At 2 MW charging, 500 kWh to go another 300 km can be delivered in about 15 minutes which is well covered by a break a driver has to take to comply with legal requirements. However, urban low-voltage 3-phase grids up to 400 V would not support this level of power.

In this scenario, local supply powered from the medium voltage regime needs to be considered as a prerequisite. Though buffering by stationary batteries is a potential option, the capacity for storage would become uneconomically large.

Working from a medium voltage transformer leads to two most promising options for chargers in a megawatt regime.

7.1. Scaling Up Stacked Subassemblies

An approach based on passenger car chargers of 350 kVA, as given in Figure 11, can be scaled up in power to serve MW-charging applications. Several subsystems are paralleled and form a charger-stack that offers the needed output power. In case subsystems of 250 kVA to 500 kVA are built, a stack of 4 to 8 units is required, as sketched in Figure 18.

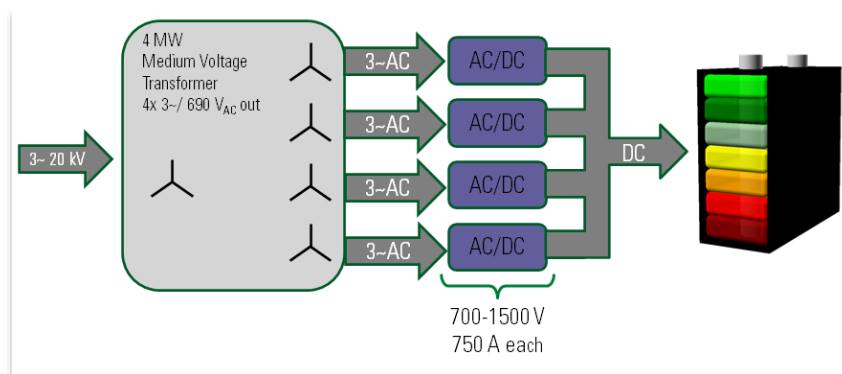

Figure 18. Structure of a MW-scale DC-Charger

The MW-realm also offers a further option, as the galvanic isolation between the battery and the supplying grid is displaced into the transformer and doesn't necessarily need to be included in the AC-DC converter.

Instead of scaling up the structure used to charge passenger cars, the same approach favored in electrolysis can be followed. Keeping in mind that thyristor-based B6C bridges only operate in step-down mode, the medium-voltage input-transformer needs to be designed with a different transfer ratio and winding scheme, as seen in Figure 19.

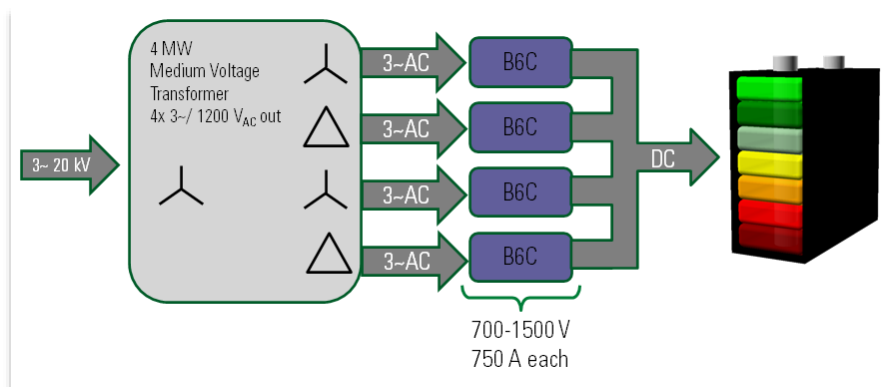

Figure 19. MW DC-Charger Based on Thyristor Bridges

Though a single B12C structure for electrolysis with only two B6 bridges, as given in Figure 8, is technically sufficient, such a system would only have limited redundancy options.

Eliminating the stage of galvanic isolation from the individual converters enhances efficiency and minimizes the number of resources per kW installed. An assembly made of presspack components also reduces space demands.

Further solutions in supplying energy to electric heavy-duty vehicles, not in the scope of this whitepaper, include dynamic wireless charging during operation^[10] and supply via overhead lines^[11].

8. Use Case IV – Construction Machines

Other than buses and trucks, construction machines like excavators, track-type loaders or bulldozers for urban construction sites set a lower priority on drivers' or passengers' comfort as they operate in rough environments. Therefore, Switched Reluctance Machines (SRM) can replace the Permanent Magnet Synchronous Machines (PMSM) in the drive train.

This machine type is a synchronous machine but doesn't need the permanent magnets; the mechanically simpler design and the absence of exotic magnetic materials leads to a better ratio of Nm/\$. The torque-density is slightly below that of a PMSM but the lack of magnets on the rotor's surface allows for a much higher rotational speed.

As the name implies, SRMs are characterized by an operation mode similar to stepper-motors. Because of the perceptible vibration and audible noise, they are not the primary choice in applications that place a higher priority on driving comfort.

Electronically, SRMs are 3-phased motors with three independent windings that need to be powered independently. Torque in this machine only depends on the current's amplitude. In contrast to PMSM, the current's direction is of no concern. A power electronic stage to drive a SRM therefore only consists of high- and low-side choppers, as drafted in Figure 20.

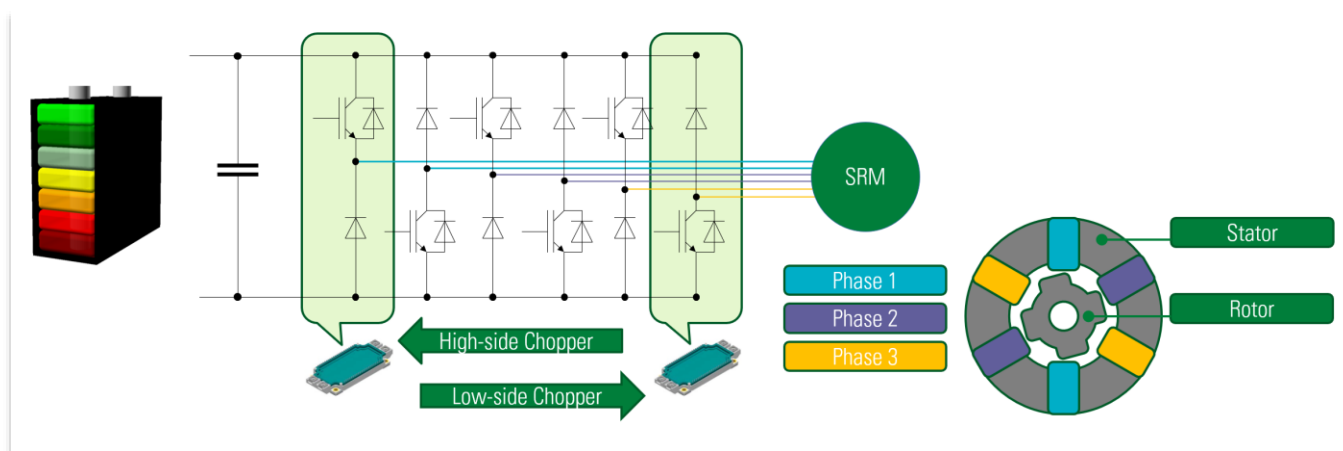

Figure 20. Power Section to Control a Switched Reluctance Motor (SRM) and a Schematical View to the Machine

A special family of construction equipment are dumpsters in large industrial mining enterprises. These vehicles with a tare weight of hundreds of tons and a payload the same size have been Diesel-electric hybrids since the 1970s^[12]. Their enormous drive trains can reach output powers in excess of 3500 HP.

Because of the unparalleled operation requirements of 23 hours or daily operation, this particular class of trucks features drive trains similar to locomotives. Operating voltages are not standardized and are in a range of up to 2.5 kV. Suitable power devices to build the power converters include high-power IGBTs in module and presspack housings but also capsule-type GTOs. An overview is given in Figure 21.

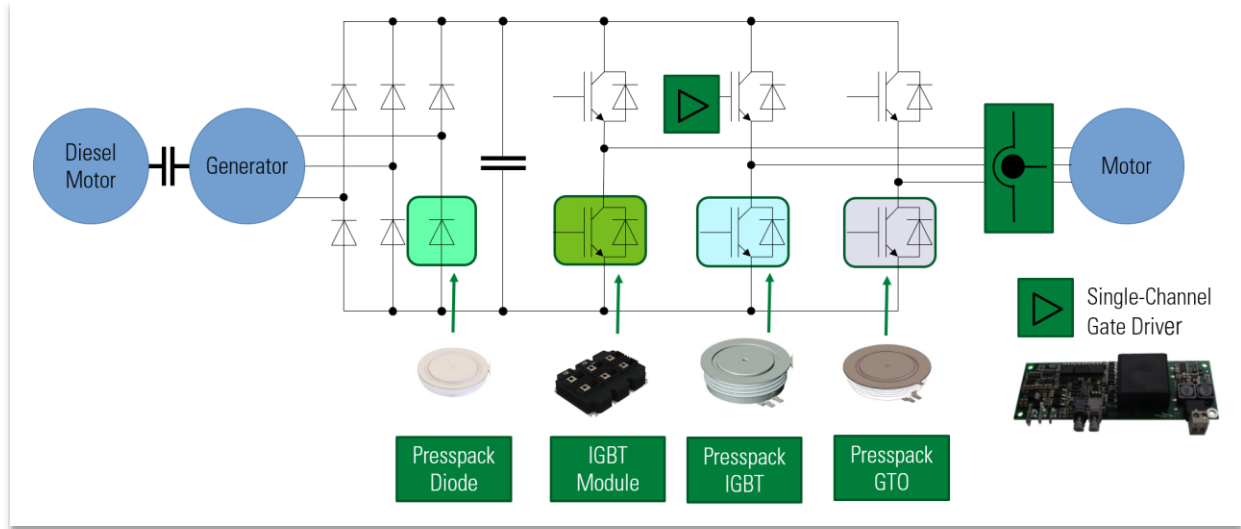

Figure 21. High-power Drive Train in Mobile MW Applications

9. Conclusion

Electrifying heavy-duty vehicles like buses, trucks, and construction equipment does not have a one-size-fits-all solution as the requirements in all use cases differ too much. However, common scenarios are seen that share similarly common approaches as solutions. The power electronic building blocks to build all the different parts of the transportation puzzle as electric versions are readily available to support any application included in the value chain from a few kW to the MW realm.

10. References

- [1] European commission, https://ec.europa.eu/clima/policies/transport/vehicles/heavy_en, visited May 12th, 2021
- [2] US Bureau of Transportation Statistics, <https://www.bts.gov/browse-statistical-products-and-data/freight-facts-and-figures/combination-truck-fuel-consumption>, visited May 12th, 2021
- [3] Bloomberg, <https://www.bloomberg.com/news/articles/2020-12-17/this-is-the-dawning-of-the-age-of-the-battery>, visited May 12th, 2021
- [4] INNOLITH AG Hirzbodenweg 95, 4052 Basel, Switzerland, <https://innolith.com/technology/>, visited May 12th, 2021
- [5] Thomas Built Buses Delivers Its 50th Electric School Bus, <https://insideevs.com/news/506038/thomas-50th-electric-school-bus/>, visited June 8th, 2021
- [6] Buses Go Truly Zero Emission with Solar Power, <https://goexplorer.org/buses-go-truly-zero-emission-with-solar-power/>, visited June 9th, 2021
- [7] Qatar home to region's first ever solar-powered bus depot, <https://www.dohanews.co/qatar-home-to-regions-first-ever-solar-powered-bus-depot/>, visited June 9th, 2021
- [8] BYD and New York Metropolitan Transportation Authority (MTA) Complete a Successful Pilot of BYD All-Electric Bus, <https://www.businesswire.com/news/home/20140108006692/en/BYD-York%C2%A0Metropolitan-Transportation-Authority-MTA-Complete-Successful#.UtRaL2RDv4V>, visited June 9th, 2021
- [9] New York School Bus Contractors Association NYSBCA, <https://www.nysbca.com/fastfacts.html>, Visited May 12th, 2021
- [10] KAIST rolling out dynamic wireless charging in buses in South Korea, <https://www.greencarcongress.com/2013/08/kaist-20130808.html>, visited June 11th, 2021
- [11] eHighway – Electrification of road freight transport, <https://www.mobility.siemens.com/global/en/portfolio/road/ehighway.html>, visited June 11th, 2021
- [12] Terex 33-19 "Titan", https://en.wikipedia.org/wiki/Terex_33-19_%22Titan%22, visited June 11th, 2021

For additional information please visit www.Littelfuse.com/powersemi

Disclaimer Notice - This document is provided by Littelfuse, Inc. ("Littelfuse") for informational and guideline purposes only. Littelfuse assumes no liability for errors or omissions in this document or for any of the information contained herein. Information is provided on an "as is" and "with all faults" basis for evaluation purposes only. Applications described are for illustrative purposes only and Littelfuse makes no representation that such applications will be suitable for the customer's specific use without further testing or modification. Littelfuse expressly disclaims all warranties, whether express, implied, or statutory, including but not limited to the implied warranties of merchantability and fitness for a particular purpose, and non-infringement. It is the customer's sole responsibility to determine suitability for a particular system or use based on their own performance criteria, conditions, specific application, compatibility with other components, and environmental conditions. Customers must independently provide appropriate design and operating safeguards to minimize any risks associated with their applications and products.

Littelfuse products are not designed for, and shall not be used for, any purpose (including, without limitation, automotive, military, aerospace, medical, life-saving, life-sustaining or nuclear facility applications, devices intended for surgical implant into the body, or any other application in which the failure or lack of desired operation of the product may result in personal injury, death, or property damage) other than those expressly forth in applicable Littelfuse product documentation. Littelfuse shall not be liable for any claims or damages arising out of products used in applications not expressly intended by Littelfuse as set forth in applicable Littelfuse documentation.

Read complete Disclaimer Notice at www.littelfuse.com/disclaimer-electronics