



Overview

The Littelfuse LPS series disconnect switch is an integrated power controller designed to meet the requirements of NFPA®70 (National Electrical Code*), NFPA 72, ANSI/ASME A17.1 (Safety Code for Elevators and Escalators), NFPA 13 (Installation of Sprinkler Systems) and other state and local jurisdiction requirements with regard to ac power for elevators.

The Littelfuse LPS series disconnect switch may be ordered in 30 A, 60 A, 100 A, 200 A or 400 A configurations, for 208, 240, 480 or 600 V ac (60 Hz), 3 or 4 wire systems. The Littelfuse LPS series disconnect switch may be configured for use as Service Equipment with the addition of a 2-port ground lug and the appropriate label per NEC Article 230.66 (option S).

Enclosures are available for the Littelfuse LPS series disconnect switches which meet NEMA 1, NEMA 3R, NEMA 4/4X and NEMA 12 standards.

The Littelfuse LPS series disconnect switch is designed to interrupt the source of incoming ac power for a single cable or hydraulic elevator, upon a signal from the Fire Alarm Control Panel (FACP). This is primarily to minimize the risk of electric shock, and to prevent impact to the mechanical safety features of an elevator, caused by water released from the fire sprinkler system.

* National Electrical Code and NEC are trademarks of their respective owners.



Description

The Littelfuse® LPS Series provides a simple and economical solution for applications that require selective coordination and shunt trip capabilities.

Utilizes Class J time-delay fuses that are easily coordinated with other system overcurrent devices. The shunt trip capability allows the LPS Series to meet the ANSI/ASME standard that requires power to be automatically disconnected before water is turned on by the fire safety system.

Applications

- Elevator circuits
- Data processing rooms
- Building emergency systems

Web Resources

Download technical information: [Littelfuse.com/lps](https://www.littelfuse.com/lps)

Specifications (Disconnect Switch)

Supply Voltage Rating*	208 V, 240 V, 480 V
Ampere Range	30 A, 60 A, 100 A, 200 A, 400 A
Enclosures	NEMA 1 (standard) NEMA 3R, NEMA 4, NEMA 12 (optional)
Approvals	UL Listed (File: E219511)

*Contact factory for 600 V options.

Specifications (Shunt Trip)

Voltage Rating	120 V, 60 Hz
Max Inrush	4 A
Max On time	1.5 cycles
Momentary Inrush	140 VA
SCCR	Refer to table on page 4.*

*Contact factory for 400 A panel SCCR

Features/Benefits

- Pre-engineered single unit, which makes procurement easier than systems with multiple components
- Reduces labor costs up to 66 % and total installation costs by over 30 %
- Pre-installed UL Listed Class J fuse holder – unique Class J size eliminates the need for any rejection type fuse clips
- Optional features offer flexibility for a variety of applications
- Color coded control power terminal blocks
- UL Listed package
- Cu and Al wire rated
- Pre-wired control circuits lower installation time
- Lockable operating handle meets all code and safety requirements (accepts up to 3 locks)
- Every unit is fully tested before delivery

Options

- Control power transformer with fuses and blocks
- Fire safety interface relay
- Key to test switch
- Pilot light "On"
- Isolated neutral lug
- Mechanical interlock auxiliary contact for hydraulic elevators with automatic recall (5 amp 120 V ac rated)
- Fire alarm voltage monitoring relay
- Enclosure
- Surge Protection Device
- Option to bypass alarm when performing maintenance (-AZ option)
- XPress-Ship™ service offers 72 hours direct shipment service on select fully loaded LPS Series Shunt Trip Disconnect Switches

LPS Series Operations & Maintenance Manual

LPS SERIES SHUNT TRIP DISCONNECT SWITCH

Ordering Information

Complete catalog numbers consist of switch catalog numbers and the desired options. See example below.

Example Catalog Number from Desired Options

LPS1 T20 R1 K G N1 B F3 U S -AZ = Littelfuse Catalog Number LPS1T20R1KGN1BF3US-AZ

LITTELFUSE SWITCH CATALOG NUMBER		CONTROL POWER TRANSFORMER STD. 100 VA WITH PRI & SEC FUSE (120 V SEC.)		"FIRE SAFETY INTERFACE RELAY (3 PDT, 10 A, 120 V)		KEY TO TEST SWITCH		PILOT LIGHT "ON"		ISOLATED NEUTRAL LUG		MECHANICAL INTERLOCK AUX. CONTACT FOR HYDRAULIC ELEVATORS WITH AUTOMATIC RECALL (5 A, 120 V AC)		FIRE ALARM SHUNT TRIP VOLTAGE MONITORING RELAY		OPTIONAL ENCLOSURE		SURGE PROTECTION DEVICE	AZ OPTION (BYPASS FIRE ALARM DURING MAINTENANCE TEST)
REQUIRED	REQUIRED	REQUIRED		OPTIONAL		OPTIONAL		OPTIONAL		REQUIRED		REQUIRED		OPTIONAL		OPTIONAL	OPTIONAL**		
BASE RATING	RATING	RATING	OPTION CODE	RATING	OPTION CODE	RATING	OPTION CODE	RATING	OPTION CODE	RATING	OPTION CODE	RATING	OPTION CODE	RATING	OPTION CODE	RATING	OPTION CODE	OPTION CODE	OPTION CODE
LPS3*	30 A	208 V	T20	24 VDC Coil	R2	120 V	K	Red	R	30 A	N6	1 NO & 1 NC	A	1-Pole	F1	NEMA 3R	U	S	-AZ
LPS6*	60 A	240 V	T24	120 VAC Coil	R1			Green	G	60 A	N6	2 NO & 2 NC	B	3-Pole	F3	NEMA 4	Y		
LPS1*	100 A	480 V	T48					White	W	100 A	N1					NEMA 12	Z		
LPS2*	200 A									200 A	N2								
LPS4*	400 A									400 A	N4								

*Part Numbers: Any voltage can be paired with any amperage. Options can be any combination but the ratings must match the option code. Not all options are required. Contact factory for 600 V control power transformer option.

** All switches with "-AZ" option automatically include option codes B and F3. The B and F3 option codes are not used in part number system but will be included in the unit.

Note: When ordering - desired options must be listed in the order shown above. Typical options include Control Power Transformer, Fire Safety Interface Relay, Mechanical Interlock Auxiliary Contact and Fire Alarm Voltage Monitoring Relay.

Dimensions of Enclosure

CATALOG SERIES	AMPERE RATING	NEMA 1 DIMENSIONS	NEMA 3R DIMENSIONS	NEMA 4, 12 DIMENSIONS	LUG SIZE	SHIPPING WEIGHT (LBS)
LPS3	30	24"H x 20"W x 9"D	24"H x 20"W x 8"D	24"H x 20"W x 10"D	#14 - #8 AL or CU	75
LPS6	60	24"H x 20"W x 9"D	24"H x 20"W x 8"D	24"H x 20"W x 10"D	#14 - #2 AL or CU	75
LPS1	100	24"H x 20"W x 9"D	24"H x 20"W x 8"D	24"H x 20"W x 10"D	#8 - 1/0 AL or CU	75
LPS2	200	30"H x 20"W x 9"D	30"H x 24"W x 8"D	30"H x 20"W x 10"D	#6 - 250 kcmil AL or CU	85, 115*, 120**
LPS4	400	48"H x 36"W x 10"D	48"H x 36"W x 12"D	48"H x 36"W x 10"D	(2) 250 kcmil - 3/0 AL or CU	225

* NEMA 3R

** NEMA 4 & NEMA 12

Note: Over-size enclosures used to accommodate control power transformer, interface relay and terminal blocks.

XPress-Ship™

US Only

Littelfuse XPress-Ship™ service offers 72 hours** direct-shipment service on select fully-loaded LPS Series Shunt Trip Disconnect Switches to meet your urgent system requirements on time.

XPress-Ship™ switches include three JTD_ID Series fuses rated at the device's maximum ampacity.

AMPERE RATING	VOLTAGE RATING	CATALOG NUMBER	XPress-Ship™ ORDERING NUMBER
60 A	208 V	LPS6T20R1KGN6BF3-AZ	XPS6T20R1KGN6F3-AZ*
60 A	480 V	LPS6T48R1KGN6BF3-AZ	XPS6T48R1KGN6F3-AZ*
100 A	208 V	LPS1T20R1KGN1BF3-AZ	XPS1T20R1KGN1F3-AZ*
100 A	480 V	LPS1T48R1KGN1BF3-AZ	XPS1T48R1KGN1F3-AZ*
100 A	480 V	LPS1T48R1KGN1BF3	XPS1T48R1KGN1BF3
200 A	208 V	LPS2T20R1KGN2BF3-AZ	XPS2T20R1KGN2F3-AZ*
200 A	480 V	LPS2T48R1KGN2BF3	XPS2T48R1KGN2BF3

*AZ option includes B & F3 options.

**XPress-Ship™ 72 hour service requires ordering from XPress-Ship™ Ordering Numbers shown above and is subject to a maximum of any combination of three switches per customer order. XPress-Ship™ service offers 72 hour shipment from the factory through standard ground transportation. For expedited delivery, contact your local Littelfuse Representative.

Shunt-Trip Operation

The disconnecting means is a shunt-trip operated switch. The control power source for the shunt-trip operator is a 120 V ac supply originating in the Littelfuse LPS Series disconnect. Current to the shunt-trip device is switched by an isolation relay, which is in turn controlled by the FACP (Fire Alarm Control Panel).

The control signal may be either 24 V dc from the FACP (option R2) or a “dry” contact closure in the FACP (option R1). In the case of a “dry” contact closure, the sensing voltage is 120 V ac originating in the Littelfuse LPS Series disconnect.

CAUTION: When using the “dry” contact closure, option R1, DO NOT supply 120 V ac from the FACP as equipment damage or personnel injury may occur.

A key test option (option K) is available to test the shunt-trip circuit.

Supervisory Indication

Additionally, an optional separate relay can be specified to monitor the 120 Vac control power source in the Littelfuse LPS Series disconnect. This relay (option FR) is used to provide supervisory indication of “Control Power Available” as required by NFPA 72 Section 6.15.4.4.

SCCR Table

CURRENT RATING	INTERRUPTING RATINGS (KA)			
	208 V AC	240 V AC	480 V AC	600 V AC
30A	150	150	65	25
60A	150	150	65	25
100A	150	150	65	25
200A	150	150	65	25

Fuse Table

DISCONNECT SWITCH VOLTAGE/TRANSFORMER TYPE	PRIMARY FUSES (2)		SECONDARY FUSE (1)		SPD PART NUMBER
	FUSE TYPE	FUSE RATING (AMPS)	FUSE TYPE	FUSE RATING (AMPS)	
208/120 V ac	KLDR001	1	FLM1.12	1-1/8	SPD2-150-3P0-R
240/120 V ac	KLDR.500	1/2	FLM1.12	1-1/8	SPD2-150-3P0-R
480/120 V ac	KLDR.400	4/10	FLM1.12	1-1/8	SPD2-350-3P0-R
600/120 V ac	KLDR.250	1/4	FLM1.12	1-1/8	SPD2-480-3P0-R

All Littelfuse LPS Series disconnect switches are UL Listed and designed for safe access by qualified personnel. When maintenance or shutdown service is required, no energized parts are exposed inside the enclosure when the disconnect switch is manually turned to the OFF position. For proper maintenance safety precautions, always turn off incoming power to the Littelfuse LPS Series switch when possible. When servicing any live electrical equipment, always wear appropriate personal protective equipment.

Power Wiring Torque Specifications

CHARACTERISTICS	LPS3	LPS6	LPS1	LPS2	LPS4
Amps	30	60	100	200	400
MCS Wire Size	14 - 1/0	14 - 1/0	14 - 1/0	4 - 300 kcmil	(2) 3/0 - 250 kcmil
Molded Case Switch (MCS) Mfr.	ABB	ABB	ABB	ABB	ABB
MCS Catalog No.	XT2HU3125DFF000XXX	XT2HU3125DFF000XXX	XT2HU3125DFF000XXX	XT4HU3250DFF000XXX	T5H400DWS4
MCS Lug Type	KXT2CUAL1	KXT2CUAL1	KXT2CUAL1	KXT4CUAL2C	KT5400-3
MCS Lug Torque (in-lbs)	50 in-lb*	50 in-lb*	50 in-lb*	200 in-lb*	275 in-lb*
Fuse Block Mfr.	LITTELFUSE	LITTELFUSE	LITTELFUSE	LITTELFUSE	LITTELFUSE
Fuse Block Catalog No.	LFJ60030-3	LFJ60060-3	LFJ60100-3	LFJ60200-3	LFJ60400-3
Fuse Lug Torque (in-lbs)	25 in-lb†	45 in-lb†	120 in-lb†	275 in-lb†	275 in-lb†
Neutral Lug Mfr.	LITTELFUSE	LITTELFUSE	LITTELFUSE	LITTELFUSE	LITTELFUSE
Neutral Lug Catalog No.	LS21211	LS21211	LS21211	LS31231	LS455712
Neutral Lug Torque (in-lbs)	35 in-lb†	45-120 in-lb†	120 in-lb†	275 in-lb†	500 in-lb†
Ground Lug Mfr.	PANDUIT	PANDUIT	PANDUIT	PANDUIT	PANDUIT
Ground Lug Catalog No.	LAMA 1/0-14-Q	LAMA 1/0-14-Q	LAMA 1/0-14-Q	LAMA 250-56-Q	LAMA 350-38-Q
Ground Lug Torque	25 in-lb‡	45 in-lb‡	120 in-lb‡	275 in-lb‡	275 in-lb‡

Note: Torque specs apply only to wire compression screws. Other requirements may exist for attachment of lugs and accessories to these devices. See manufacturer data.

*Per ABB.com

† Littelfuse Device nameplate data.

‡ Panduit, “Torque Chart for Aluminum Mechanical Connectors”.

R1 Wiring Diagram

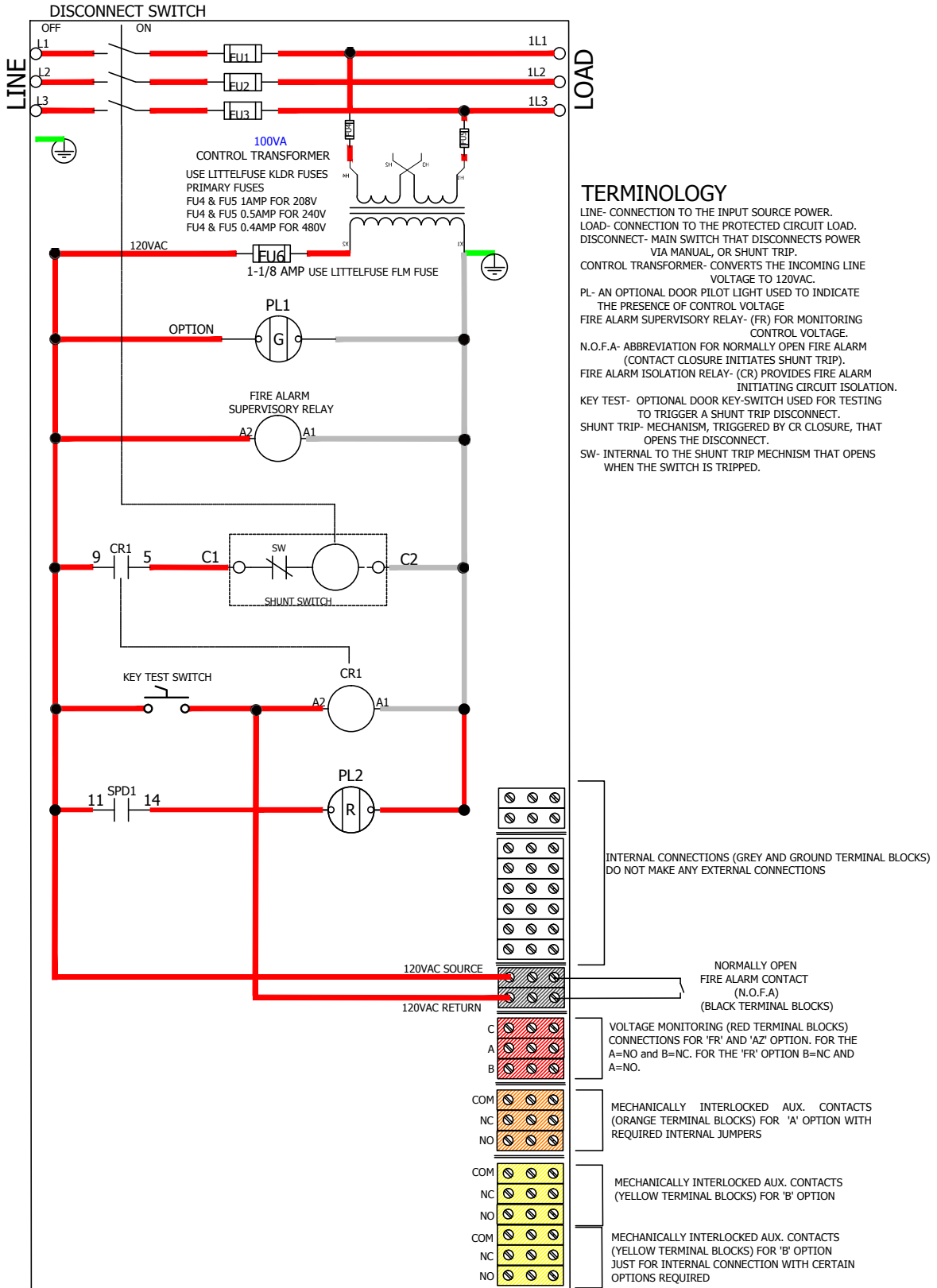

TERMINOLOGY

- LINE- CONNECTION TO THE INPUT SOURCE POWER.
- LOAD- CONNECTION TO THE PROTECTED CIRCUIT LOAD.
- DISCONNECT- MAIN SWITCH THAT DISCONNECTS POWER VIA MANUAL, OR SHUNT TRIP.
- CONTROL TRANSFORMER- CONVERTS THE INCOMING LINE VOLTAGE TO 120VAC.
- PL- AN OPTIONAL DOOR PILOT LIGHT USED TO INDICATE THE PRESENCE OF CONTROL VOLTAGE
- FIRE ALARM SUPERVISORY RELAY- (FR) FOR MONITORING CONTROL VOLTAGE.
- N.O.F.A- ABBREVIATION FOR NORMALLY OPEN FIRE ALARM (CONTACT CLOSURE INITIATES SHUNT TRIP).
- FIRE ALARM ISOLATION RELAY- (CR) PROVIDES FIRE ALARM INITIATING CIRCUIT ISOLATION.
- KEY TEST- OPTIONAL DOOR KEY-SWITCH USED FOR TESTING TO TRIGGER A SHUNT TRIP DISCONNECT.
- SHUNT TRIP- MECHANISM, TRIGGERED BY CR CLOSURE, THAT OPENS THE DISCONNECT.
- SW- INTERNAL TO THE SHUNT TRIP MECHANISM THAT OPENS WHEN THE SWITCH IS TRIPPED.

R2 Wiring Diagram

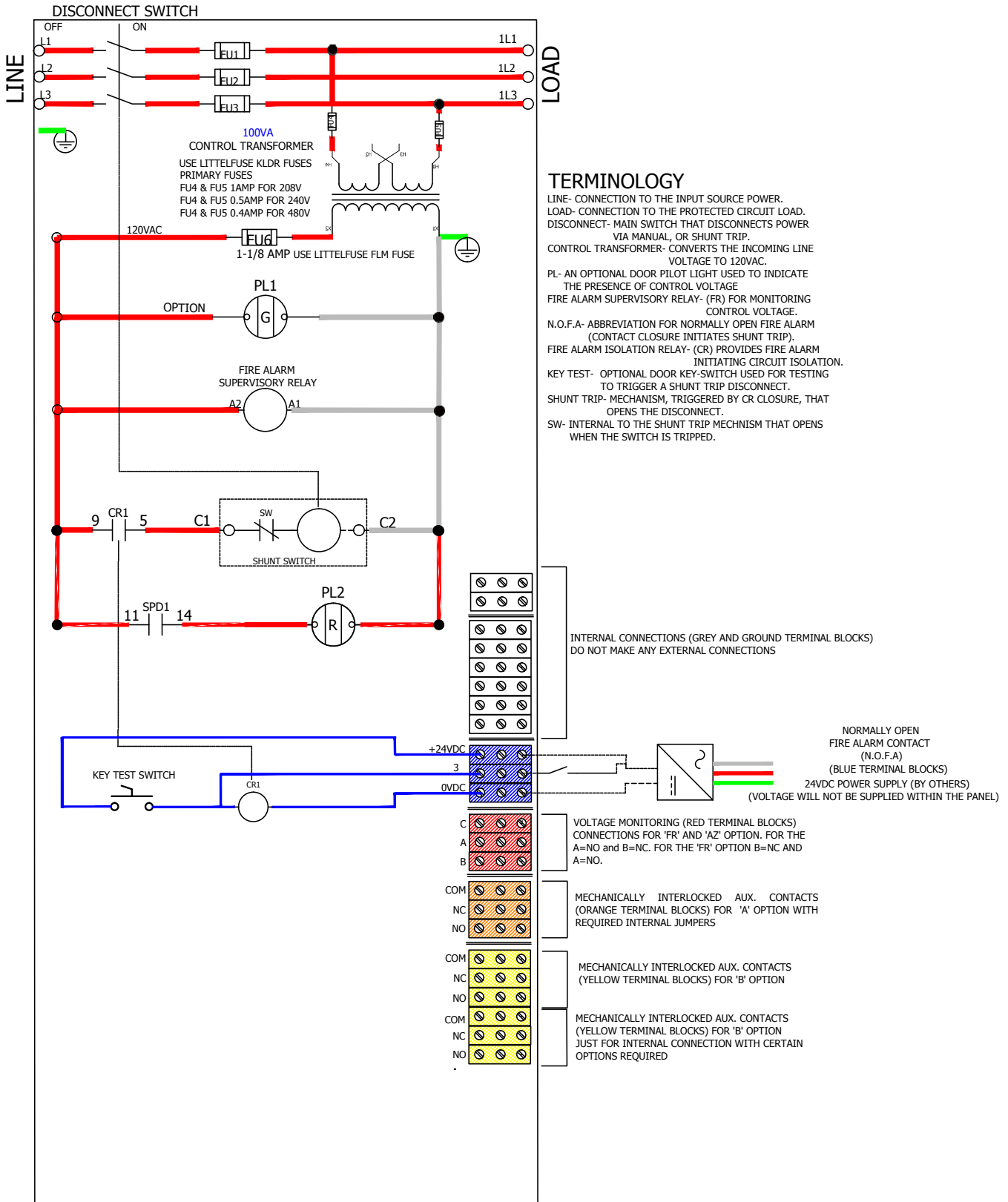

TERMINOLOGY

LINE- CONNECTION TO THE INPUT SOURCE POWER.
LOAD- CONNECTION TO THE PROTECTED CIRCUIT LOAD.
DISCONNECT- MAIN SWITCH THAT DISCONNECTS POWER VIA MANUAL, OR SHUNT TRIP.
CONTROL TRANSFORMER- CONVERTS THE INCOMING LINE VOLTAGE TO 120VAC.
PL- AN OPTIONAL DOOR PILOT LIGHT USED TO INDICATE THE PRESENCE OF CONTROL VOLTAGE
FIRE ALARM SUPERVISORY RELAY- (FR) FOR MONITORING CONTROL VOLTAGE.
N.O.F.A- ABBREVIATION FOR NORMALLY OPEN FIRE ALARM (CONTACT CLOSURE INITIATES SHUNT TRIP).
FIRE ALARM ISOLATION RELAY- (CR) PROVIDES FIRE ALARM INITIATING CIRCUIT ISOLATION.
KEY TEST- OPTIONAL DOOR KEY-SWITCH USED FOR TESTING TO TRIGGER A SHUNT TRIP DISCONNECT.
SHUNT TRIP- MECHANISM, TRIGGERED BY CR CLOSURE, THAT OPENS THE DISCONNECT.
SW- INTERNAL TO THE SHUNT TRIP MECHANISM THAT OPENS WHEN THE SWITCH IS TRIPPED.

Preventive Maintenance

- Periodically check torque on the wire compression screws in the power circuit. The chart included has the torque values for the various models.
- Annual review of LPS Series Shunt Trip Disconnect Switch is recommended. ABB has no specific maintenance recommendations. Otherwise, predictive maintenance could be done by thermal-scan, either with an IR imager or a non-contact temperature sensor.
- Any unexpected temperature increase, not related to load variations or ambient temperature could signal a problem with lug torque.
- Maximum temperature at any lug should never exceed 75 degrees C under any conditions.
- Clean and periodically dust product throughout the year.

Frequently Asked Questions

What UL listings does the Littelfuse LPS Series have?

The LPS Series unit is UL Listed to UL 98. The molded case switch used within the LPS is UL Listed to UL 489.

What codes and standards does the Littelfuse LPS Series meet?

The LPS Series meets several NEC, NFPA 72, and ANSI/ASME standards. Please refer to Littelfuse product literature for more details.

How does the Mechanical Auxiliary Contact Option (Option A) work?

The "A" Option is a set of auxiliary contacts that are mechanically interlocked to the main switch. These contacts are generally used for auxiliary power interface such as battery lowering. The contacts are used to signal initiation of auxiliary power in the event of power loss. The contact is a single pole, double throw (SPDT) contact. It is important to note that these contacts differentiate between manually turned off or shunted off. (Refer to the table below)

LPS SWITCH	STATE OF AUX CONTACTS	
	NO (ORANGE TB, NO & COM)	NC (ORANGE TB, COM & NC)
Off	0	X
On	X	0
Shunted	X	0

0 = Off X = On

How does the Mechanical Auxiliary Contact Option (Option B) work?

The "B" Option is two sets of auxiliary contacts that are mechanically interlocked to the main switch. These contacts are generally used to monitor the status of the switch. The contacts are double pole, double throw (DPDT) contacts. It is important to note that these contacts will follow the state of the switch. (Refer to the table below)

LPS SWITCH	STATE OF CONTACTS	
	NO (YELLOW TB, COM & NO)	NC (YELLOW TB, COM & NC)
Off	0	X
On	X	0
Shunted	0	X

0 = Off X = On

How does the AZ Option (Option -AZ) work?

Internal wiring between the molded case switch's auxiliary contacts and the fire relay's contacts implements a logic circuit that monitors the availability of shunt trip power. Terminals C & A close only if the main switch is on and the shunt trip power fails. They will not close if the main switch is manually turned off for maintenance, preventing a false alarm. (Refer to table below)

LPS SWITCH	STATE OF AUXILIARY CONTACTS	
	RED TERMINAL BLOCK A & C	RED TERMINAL BLOCK B & C
Off, Power Available	0	X
On, Power Available	0	X
Off, No Power	0	X
On, No Power	X	0

0 = Off X = On

- Does the instantaneous trip feature built into the molded case switch create the potential to strand passengers when used on circuits with hydraulic elevators and auxiliary battery lowering?**
- The shunt trip mechanism within the switch is utilized, not the instantaneous trip feature of the switch. Even in the event of an instantaneous trip condition, the alarm relay will respond the same as when the switch is shunted off. There is no potential for stranding passengers when Littelfuse LPS Series units are installed with the Mechanical Interlock Auxiliary Contact Option (Option A, battery back-up feature).
- During a power loss, will the state of the switch change state?**
- The LPS Series will not change state. However, units installed with the Mechanical Interlock Auxiliary Contact Option (Option A) will distinguish between turned off and shunted off and send a signal accordingly to the fire alarm controller.
- How does the LPS Series decide when the elevator needs to be lowered?**
- The Littelfuse LPS Series does not make that decision. The LPS Series provides a signaling means to the fire alarm controller. The fire alarm controller makes all decisions regarding when and where the elevator is to be lowered.
- Does the fire safety relay monitor the voltage required by NFPA 72?**
- No, the fire safety relay option (Littelfuse Option R1 or R2) does not monitor voltage. Littelfuse offers both a fire safety relay and fire alarm voltage monitoring relay options. The Littelfuse Fire Alarm Voltage Monitoring Relay (F1/F3 option) does meet NFPA 72 (National Fire Alarm Code) requiring control circuits to be monitored for presence of voltage. The Littelfuse unit is wired to sense the voltage available to initiate the shunt-trip. It will change state if a power loss occurs. It does not rely on the shunt-trip itself.
- Does the Littelfuse LPS Series require any periodic maintenance?**
- No specific maintenance is required. However, like most electrical equipment, it is always a good idea to periodically check wire connections for proper torque and ensure fuse clips are clean and tight. Please refer to the Preventive Maintenance section of this document for more details.
- How do you hook up the dry contacts for the battery back-up option?**
- This will depend on how the Mechanical Auxiliary Contact (Option A) will be connected. The A Option will follow the ON/OFF of the switch when the handle is in the off position. The "COM" and "NC" of the ORANGE terminal blocks will be used when following the NC contacts. The "COM" and "NO" of the ORANGE terminal blocks will be used when following the NO contacts. the NC contacts. Terminals 9 & 10 will be used when following the NO contacts.
- Where do you land the power for the shunt trip on the terminal strip?**
- This will vary if using the R1 Option (120 VAC) or the R2 Option (24 Vdc). The BLACK terminal blocks will be used for the R1 Option. The BLUE terminal blocks will be used for the R2 Option. Refer to the R1 & R2 drawings for more details.
- Where does the fire alarm get connected for monitoring the status of the switch?**
- This will vary on which option is being utilized (A or B). Option A will use the ORANGE terminal blocks (COM, NC & NO). Option B will use the top set of YELLOW terminal blocks (COM, NC & NO).
- How do I connect to the fire alarm voltage-monitoring relay?**
- This is commonly referred to as the FR relay and is Littelfuse Option F1 or F3. The RED terminal blocks (C, A & B) are used for this purpose.
- If an LPS Series is ordered with a wrong component, can the component be changed in the field?**
- No. To comply with UL guidelines, product modifications can only be completed by authorized factory personnel. Other modifications will void the Littelfuse UL listing.
- Can the LPS Series be used as a service entrance switch?**
- The Littelfuse LPS Series is UL Listed per UL 98. Yes, it can be used as a service entrance if properly labeled as such.



Can the LPS Series be fed in reverse with the line from the bottom and load out the top of the switch?

No, the LPS Series will not properly function.

When connecting the LPS Series to the fire alarm, what do you do with the neutral?

There is no need to tie into the neutral. LPS Series units equipped with a Control Power Transformer (CPT) will supply 120 volts.

Can the LPS Series be used in an application with no fire alarm and can a smoke detector be connected instead?

No, this is not in accordance with the fire code.

Does the FR Relay (Option F1 or F3) change state during a power loss?

Yes, the FR relay will always change state. The FR relay is designed to monitor voltage that is available for the shunt trip. This is a requirement of NFPA 72.

Is the operating handle of the LPS Series lockable in the "off" position only?

Yes, the handle can only be locked from the "off" position and can accommodate a maximum of three padlocks.

What enclosures are available for the LPS Series?

All ratings of the LPS Series come standard with a UL (NEMA) type 1 enclosure. Optional enclosures include UL (NEMA) type 3R, 4, and 12.

Is a CPT always required in an LPS Series?

In most cases, a CPT will be required to supply the 120 Vac for shunt tripping.

How is the Littelfuse LPS Series typically shipped and how much do they weigh?

The form of shipment will depend on the number of units ordered. Large quantities are typically shipped via truck and smaller quantities shipped via UPS or FedEx. Depending on options, 30-100 amp units weigh approximately 70 pounds and 200 amp units weigh around 85 pounds. 400 amp units weigh over 200 pounds and can only be shipped via truck.

What kind of fuses does Littelfuse recommend?

UL Listed Class J JTD or JTD_ID fuses. The fuse holders installed in the panels are made to accommodate this fuse type. These fuses provide good short circuit and motor load protection. For fuse sizing see NEC Article 430.52 which, in effect, says motor branch circuit fuses of the time-delay type may be sized for up to 175% of the motor full load amps.

What is the warranty for the LPS Series?

Under most circumstances, there is a one-year warranty. Please contact your local Littelfuse Sales Representative if you have any questions or a unique situation.

I need a part number that is not listed on the XPress-Ship Program. Can I get an expedited shipment service?

Yes, Littelfuse offers expedite shipment service for part numbers outside the XPress-Ship Program.

Contact your Littelfuse Customer Service Team for pricing and availability.

I have a repeat order for an XPress-Ship Program part number I have ordered in the past. Can I get the same part number in standard shipment service?

Yes, you may request standard shipment service by substituting the ordering part number prefix 'XPS' with 'LPS'

Example:

XPress-Ship ordering number: **XPS6T48R1KGN6F3-AZ**

Standard shipment ordering number: **LPS6T48R1KGN6F3-AZ**

Can I get the XPress-Ship program product I ordered air shipped?

Yes, you may request air shipment when booking the order, however the customer would be responsible for all charges involved for air shipment.

I need 10 units of a specific part number from the XPress-Ship Program. Can I get the program's 72 hour service on all units?

No, XPress-Ship 72 hour service is limited to three switches per customer order.

Contact your Littelfuse Customer Service Team for availability in scenarios such as this.

Do I need to order fuses separately, when I place an order for a part number in XPress-Ship Program?

No, all part numbers offered through XPress-Ship include three pre-installed JTD_ID Series fuses rated at the device's maximum ampacity.

Example:

XPS2T48R1KGN2BF3 is a 200 A switch and ships with three 0JTD200.XXID fuses installed.

Note: When ordering LPS Series in standard shipment service, fuses must be ordered separately.

Can I receive a fuse rating other than the maximum rating supplied with the switch in the XPress-Ship Program?

No, switches in the XPress-Ship Program are offered with fuses pre-installed and rated to the maximum ampere rating of the switch.

Customers may request a different fuse rating while booking the order and those will be charged and shipped separately, but are not included under the XPress-Ship Program Service Terms.

Can I monitor of the status of the SPD with the panel closed?

Yes, the SPD option comes with a red pilot light on the door of the panel.