



Expertise Applied | Answers Delivered

In-Vehicle Communication



Passenger Vehicle

Users must independently evaluate the suitability of and test each product selected for their own specific applications. It is the User's sole responsibility to determine fitness for a particular system or use based on their own performance criteria, conditions, specific application, compatibility with other parts, and environmental conditions. Users must independently provide appropriate design and operating safeguards to minimize any risks associated with their applications and products. Littelfuse products are not designed for, and may not be used in, all applications. Read complete Disclaimer Notice at littelfuse.com/disclaimer-electronics.

Automotive E/E architecture evolution:

Moving from conventional architecture → domain architecture → zonal architecture

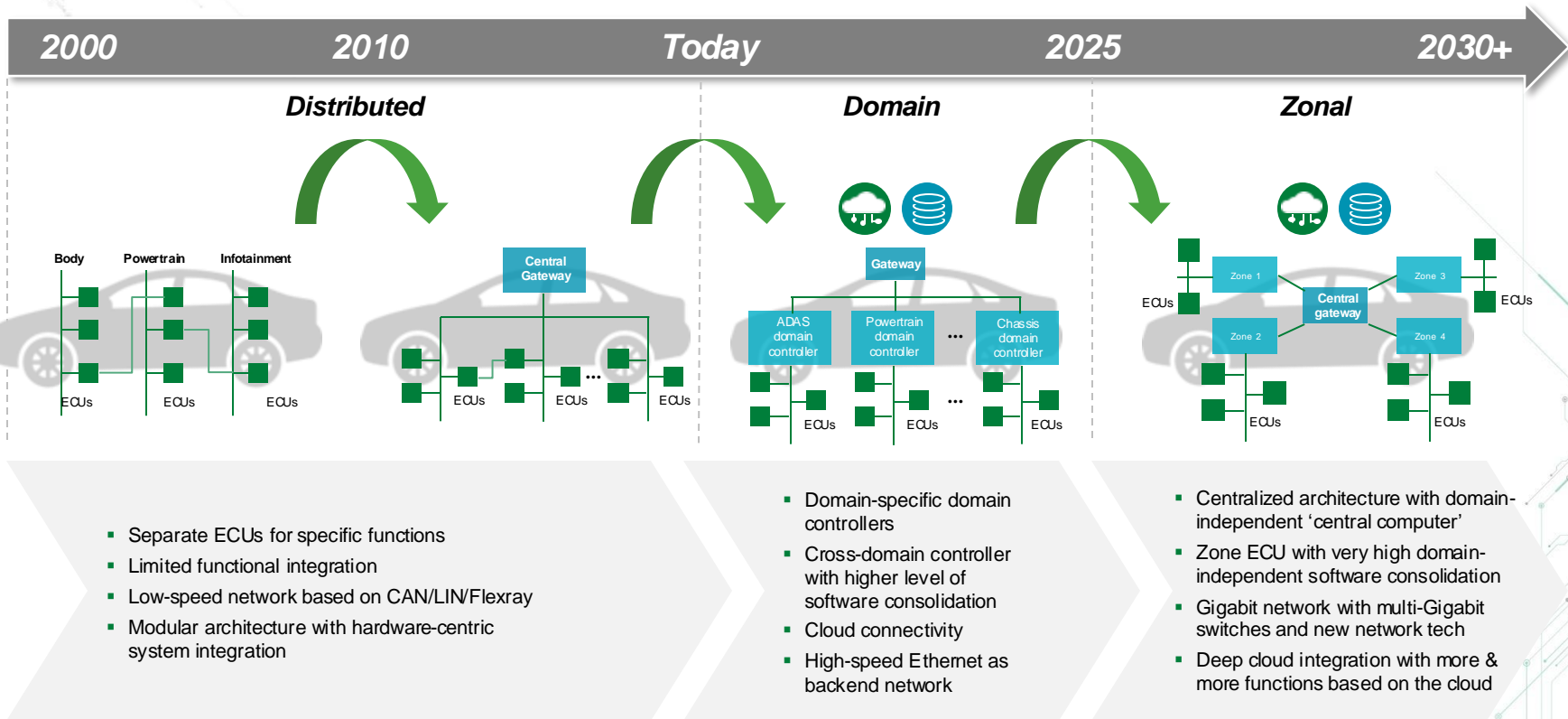

Zonal architecture is the future of automotive in-vehicle communication

Domain architecture

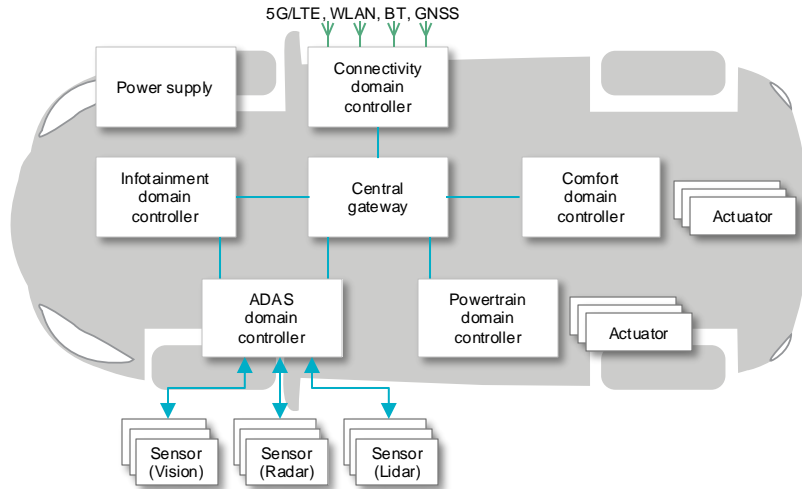

- Domain architecture controls and divides by function
- Computation can be performed locally
- Challenging if the sensors and devices are farther from control module
- Need additional wiring and interfaces

Zonal architecture

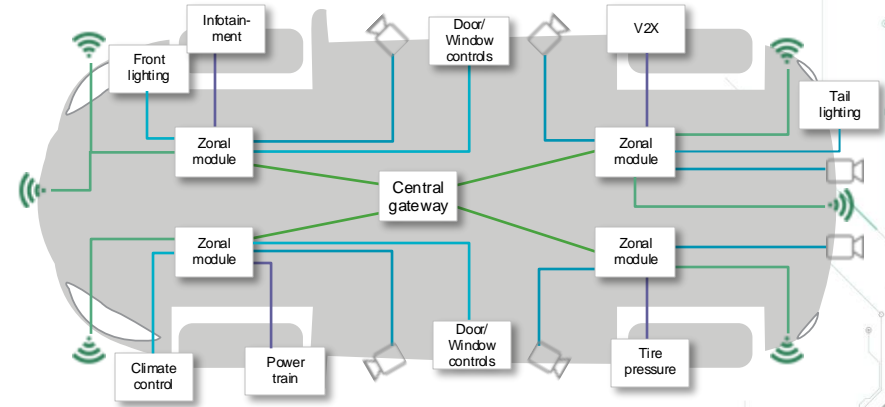

- Software-based approach
- A central computer is linked to sensors and devices through zonal gateways
- Offers better scalability
- Simplifies cabling and improves reliability

Zonal Control Unit (ZCU)/Zonal Gateway block diagram

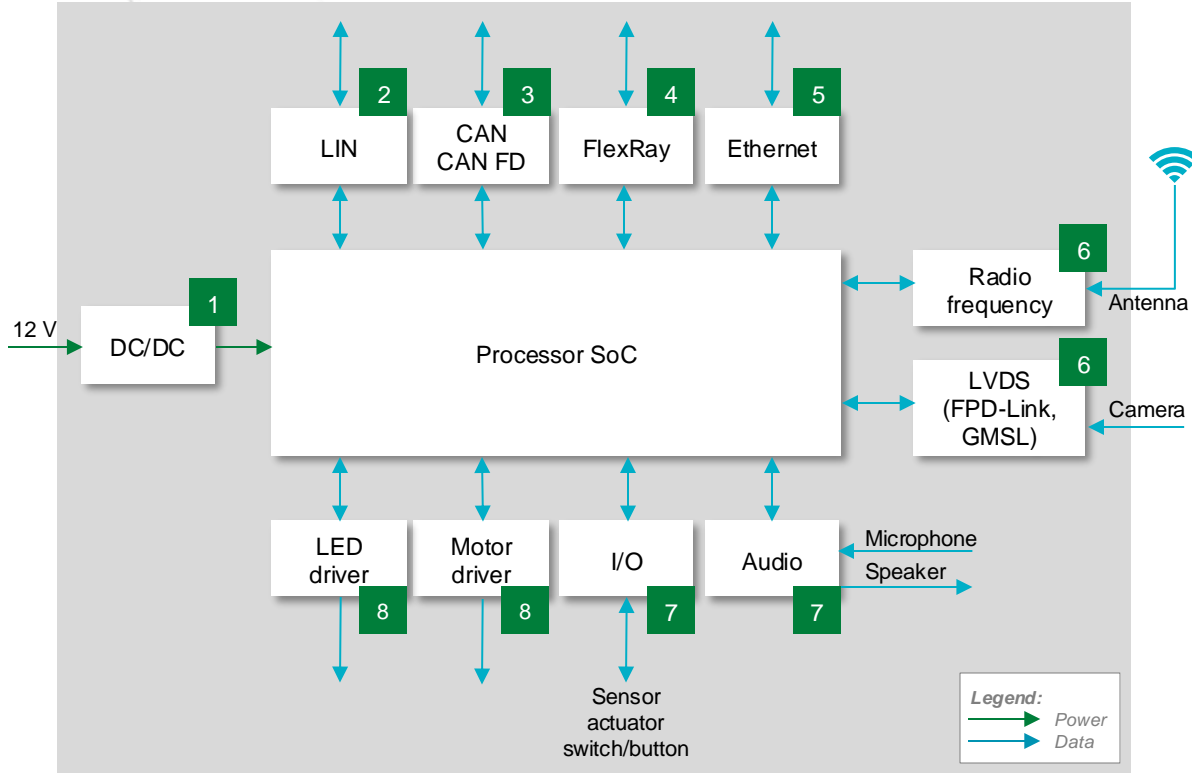

	Technology	Series
1	Fuse	437A , 440A , 441A
	PPTC	ASMD , miniASMD
2	TVS Diode	TPSMC , SLD8S , SZ1SMA , SZSMF4L
	MOV	AUML , MLA Auto
3	Schottky Diode	DST
	TVS Diode Array	AQ24-01FTG
4	TVS Diode Array	AQ24COM-02 , AQ24CANFD
	TVS Diode Array	AQ24CANFD
5	TVS Diode Array/ Polymer ESD	AQ24ETH-02HTG/ AXGD
	TVS Diode Array/ Polymer ESD	AQ3130 , AQ3118/ AXGD
6	TVS Diode Array	AQ1003 , AQ1005 , AQ3522
	MOV	MLA Auto
7	TVS Diode	TPSMB , TP6KE , SZSMF4L , SZ1SMA
	TVS Diode	

Potential Littelfuse products for Zonal Control Unit (ZCU)/Zonal Gateway

 Click the product series in the table below for more info

	Technology	Function in application	Product series	Benefits	Features
1	Fuse	Short circuit protection	437A, 440A, 441A	Excellent temperature stability and performance reliability; compact design	Tested to new AECQ specification; fast response to fault current; surface mount device
	PPTC		ASMD, miniASMD	Meets automotive standards; compact design	AEC-Q200 qualified; small footprint 2029/1812 size
	TVS Diode	Load dump protection	TPSMC, SLD8S, SZ1SMA, SZSMF4L	Excellent clamping capability; fast response time; compact design	AEC-Q101 qualified; meets IEC standards for ESD protection and ISO for load dump protection
	MOV		AURL, MLA Auto	Offers rugged protection and excellent transient energy absorption; compact design	AEC-Q200; load dump energy rated per SAE Specification J1113; surface mount device
	Schottky Diode	Reverse blocking/output rectification	DST	Enables the design of high-efficiency power supplies by eliminating reverse polarity condition	Ultra-low Vf; high temperature capability; low forward voltage drop to 100 V and 10 A
2	TVS Diode Array	LIN Bus protection	AQ24-01FTG	Clamp transient to a safe level preventing catastrophic failure; compact design	Low capacitance 30 pF and leakage current (0.1 μA); small form factor SOD882
3	TVS Diode Array	CAN Bus protection	AQ24COM-02, AQ24CANFD	Ensures reliability of the equipment without performance degradation	AEC-Q101 qualified; low leakage current and clamping voltage
4	TVS Diode Array	FlexRay protection	AQ24CANFD	Ensures reliability of the equipment without performance degradation	AEC-Q101 qualified; low leakage current and clamping voltage
5	TVS Diode Array	Ethernet protection	AQ24ETH-02HTG	Approved by OPEN Alliance 100/1000 BASE-T1 Ethernet	Safely absorb repetitive 1,000 times ESD strikes with ±30 kV contact discharge (ISO 10605)
	Polymer ESD		AXGD	Preserve signal integrity; withstand high levels of ESD	AEC-Q200 qualified; ultra-low capacitance; low leakage current
6	Polymer ESD	ESD protection for antenna, WiFi, and another chipset	AXGD	Preserve signal integrity; withstand high levels of ESD	AEC-Q200 qualified; ultra-low capacitance; low leakage current
	TVS Diode Array		AQ3130, AQ3118	Back-to-back configuration allows usage in RF circuits	AEC-Q101 qualified; low capacitance; low leakage current; small form factor
7	TVS Diode Array	ESD protection for audio amplifier	AQ1003, AQ1005, AQ3522	Clamp transient to a safe level preventing catastrophic failure; compact design	Low capacitance 30 pF; leakage current (0.1 μA); small form factor SOD882
	MOV	I/O protection	MLA Auto	Offers rugged protection and excellent transient energy absorption; compact design	AEC-Q200; load dump energy rated per SAE Specification J1113; surface mount device
8	TVS Diode	ESD protection for LED Driver	TPSMB, TP6KE, SZSMF4L, SZ1SMA	Excellent clamping capability; fast response time; compact design	AEC-Q101 qualified; meets IEC standards for ESD protection and ISO for load dump protection

Automotive Ethernet is the backbone of zonal architecture

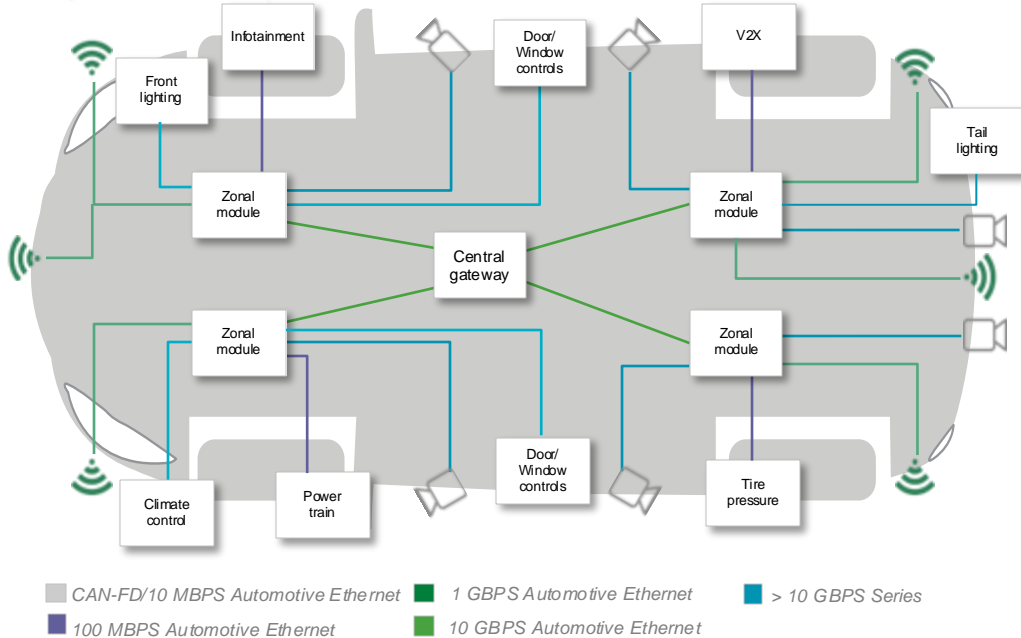

Automotive Ethernet standards:

OPEN ALLIANCE	10Base-T1S IEEE 802.3cg	100Base-T1 IEEE 802.3bw	1000Base-T1 IEEE 802.3bp	MGBase-T1 IEEE 802.3ch
Data rate	10 Mbps	100 Mbps	1,000 Mbps	2.5/5/10 Gbps
Symbol rate	12.5 MHz	66 MHz	750 MHz	1.4/2.8/5.6 GHz
Distance	1,000 m	40 m	40 m	15 m
#Lanes	1	1	1	1

Comparison of technologies:

Features	Automotive Ethernet	CAN/CAN-FD/CAN-XL	LIN
Data rate	10 Mbps–10 Gbps	1 Mbps (CAN) 8 Mbps (CAN-FD) 20 Mbps (CAN-XL)	20 Kbps
Applications	ECU interconnect, camera, radar, infotainment	ABS, powertrain, engine control	Electric seats, mirror adjustments

[OPEN Alliance SIG](#) is a non-profit industry alliance of mainly automotive industry and technology providers formed to enable wide-scale adoption of Ethernet connectivity as the standard in automotive networking applications.

ESD protection requirements for the automotive Ethernet as defined by the OPEN Alliance

Arrangement of ESD suppression device

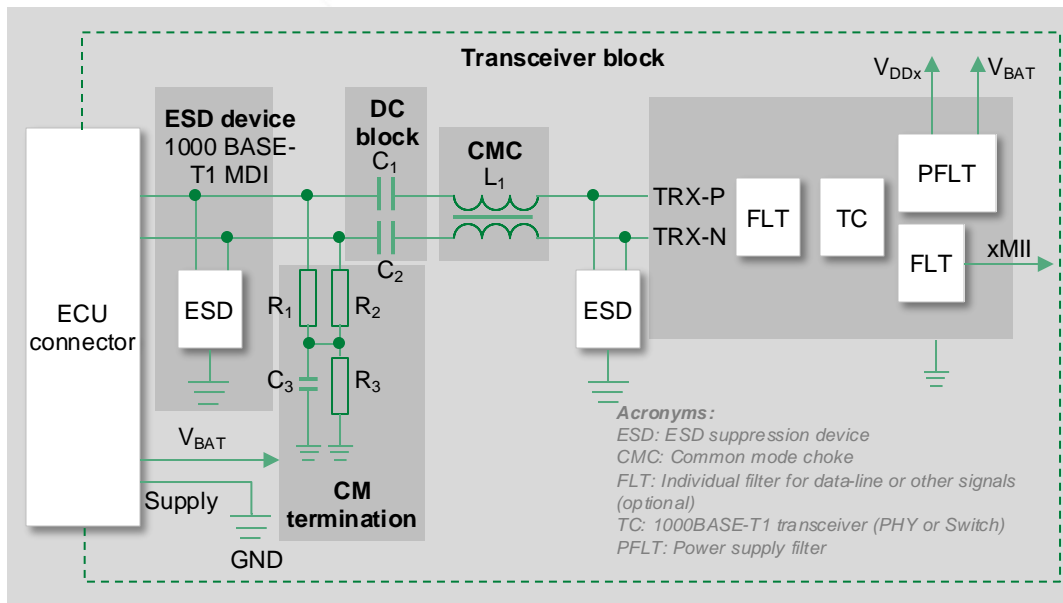

Target values for ESD suppression device

Parameter	Target value
Working direction	Bi-directional
Operation voltage (V_{DCmax})	≥ 24 V
ESD trigger voltage	≥ 100 V (Required because the ESD device should not be triggered by serious RF transmissions).
ESD robustness against damage	± 15 kV contact discharge for unpowered device using discharge module according to ISO 10605 (discharge storage capacitor $C = 150$ pF and discharge resistor $R = 330$ Ω).
Minimum number of discharges	$> 1,000$
TLP characteristic according to [IEC1]	I/V characteristics

- [10BASE-T1S EMC Test Specification for ESD Suppression Devices](#)
- [100BASE-T1 EMC Test Specification for ESD Suppression Devices](#)
- [1000BASE-T1 ESD Device Test Specification](#)

Littelfuse ESD protection solutions for the automotive Ethernet

Click the product series in the table below for more info

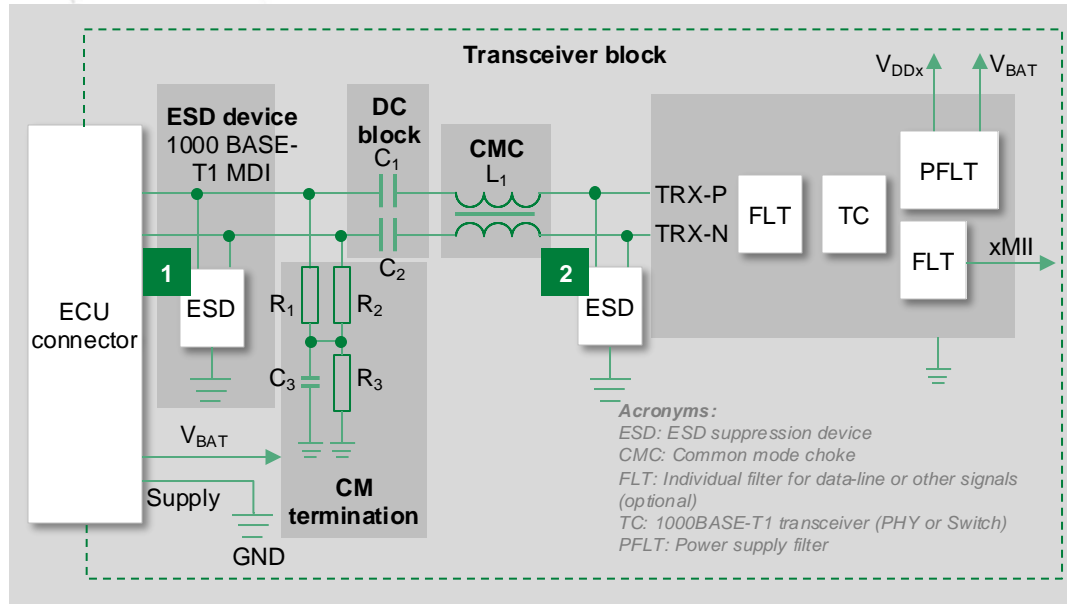

	Technology	Product series
1	Polymer ESD Suppressor	AXGD
	TVS Diode Array	AQ24ETH-02HTG (Q2 2024 release)
2	TVS Diode Array	AQ3400 , SESD

Littelfuse ESD protection solutions comparison for the automotive Ethernet

Parameter	Target value	AXGD	AQ24ETH-02HTG (Q2 2024 release)
Working direction	Bi-directional	Bi-directional	Bi-directional
Operation voltage (V_{DCmax})	≥ 24 V	32 V max.	27 V
ESD trigger voltage	≥ 100 V	250 V	160 V
ESD robustness against damage	± 15 kV contact discharge for unpowered device using discharge module according to ISO 10605 (discharge storage capacitor $C = 150$ pF and discharge resistor $R = 330 \Omega$)	30 kV	30 kV
Minimum number of discharges	$> 1,000$ pulses	$> 1,000$ pulses	$> 1,000$ pulses
Link to the datasheet	-	AXGD Datasheet	Contact Littelfuse Sales

AQ24ETH-02HTG is approved by OPEN Alliance to protect 100/1,000 BASE-T1 Ethernet against ESD



CAN Bus overview and ESD requirements

Arrangement of ESD suppression device

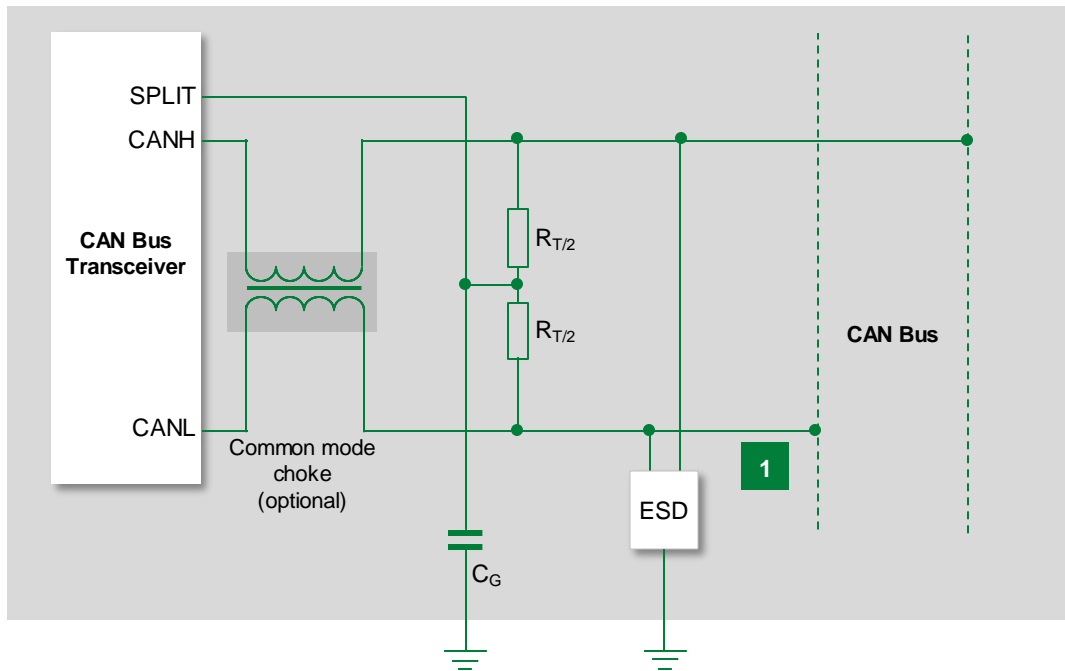

CAN Bus characteristics and ESD specifications

Features	High-speed CAN	Low-speed CAN
Physical layer	ISO 11898-2	ISO 11898-3
Data rate	1 Mbps (CAN) Up to 5 Mbps (CAN-FD) Up to 20 Mbps (CAN-XL)	Up to 125 Kbps
Cable length	30 m	500 m
Min./Max. supply voltage	12 V System: -3/16 V	24 V System: -3/32 V
Termination resistance	120 Ω shunt	2.2 kΩ serial on each line
Common mode voltage (V)	min./nom./max. CAN_L: -2.0/2.5/ CAN_H: _/2.5/7.0	min./nom./max. CAN_L: -2.0/2.5/ CAN_H: _/2.5/7.0

Standards	CAN protection specification
ISO 10605 (ESD protection)	ESD robustness up to 30 kV (R = 330 Ω, C = 330 pF) and low ESD clamping voltage
ISO 7637-3 pulse 3a/3b (Surge protection)	Must pass the surge test
ISO 16750 (Jump start)	Reverse breakdown voltage VBR > 24 V
ISO 16750 (Reverse battery)	Forward breakdown voltage VBR < -14 V for 12 V battery. Forward breakdown voltage VBR < -28 V for 24 V battery

Littelfuse solutions for CAN Bus ESD protection

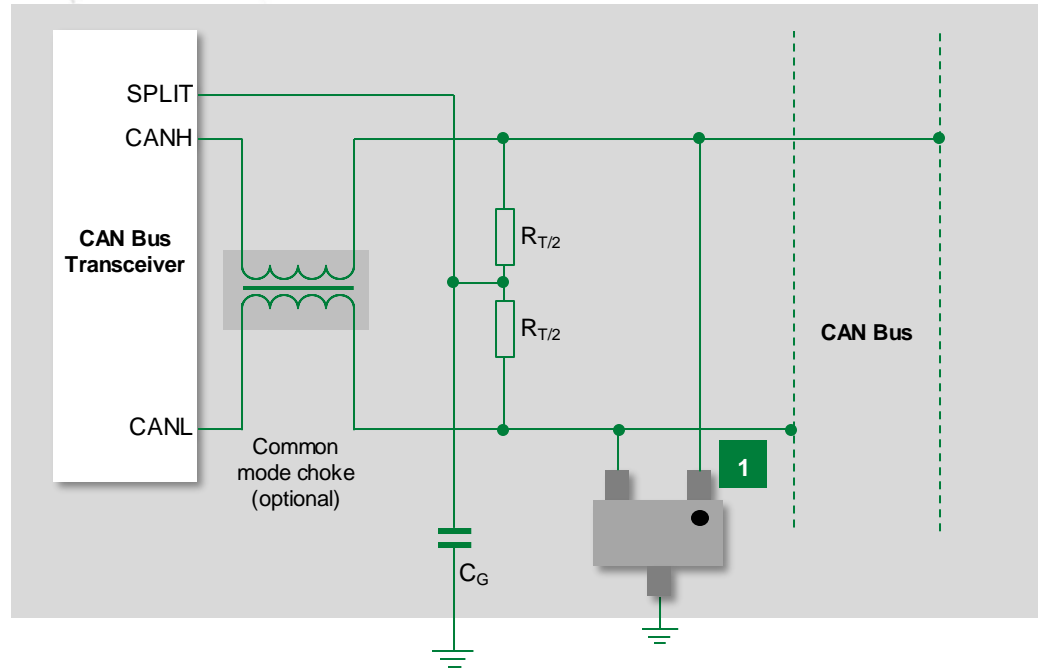

	Technology	Product series
1	TVS Diode Array	AQ24CANA-02HTG , AQ24COM-02 , AQ24COM-01

Littelfuse ESD protection solution comparison for CAN Bus

Standard	CAN protection specification	AQ24CANA-02HTG	AQ24COM-02	AQ24COM-01
ISO 10605 (ESD protection)	ESD robustness up to 30 kV (R = 330 Ω, C = 330 pF) and low ESD clamping voltage	330pF 330Ω, ±27kV contact, ±30kV air	330 pF 330 Ω, ±30 kV contact/air	330 pF 330 Ω, ±30 kV contact/air
ISO 7637-3 pulse 3a/3b (Surge protection)	Must pass the surge test	ESD, IEC 61000-4-2, ±27kV contact, ±30kV air EFT, IEC 61000-4-4, 50A (5/50ns) Lightning, 5A (8/20μs as defined in IEC 61000-4-5 2 nd edition)	ESD, IEC 61000-4-2, ±30 kV contact/air EFT, IEC 61000-4-4, 40 A (5/50 ns) Lightning, 5A (8/20μs as defined in IEC 61000-4-5 2 nd edition)	ESD, IEC 61000-4-2, ±30 kV contact/air EFT, IEC 61000-4-4, 40 A (5/50 ns) Lightning, 5A (8/20μs as defined in IEC 61000-4-5 2 nd edition)
ISO 16750 (Jump start)	Reverse breakdown voltage VBR > 24 V	24 V	24 V	24 V
ISO 16750 (Reverse battery)	Forward breakdown voltage VBR < - 14 V for 12 V battery. Forward breakdown voltage VBR < -28 V for 24 V battery	28 V	33 V	33 V
Link to the datasheet		AQ24CANA-02HTG Datasheet	AQ24COM-02 Datasheet	AQ24COM-01 Datasheet

Select standards for automotive applications

Standard	Title	General scope	Littelfuse technology	Region
ISO7637-2	Road vehicles – electrical disturbances from conduction and coupling – Part 2: Electrical transient conduction along supply lines only	Specifies test methods and procedures to ensure the compatibility to conducted electrical transients of equipment installed on passenger cars and commercial vehicles fitted with 12 V or 24 V electrical systems. It describes bench tests for both the injection and measurement of transients. It is applicable to all types of road vehicles independent of the propulsion system (for example, spark ignition or diesel engine, and electric motor).	TVS Diode	Global
ISO16750-2	Road vehicles – environmental conditions and testing for electrical and electronic equipment – Part 2: Electrical loads	This standard applies to electric and electronic systems/ components for road vehicles. It describes the potential environmental stresses and specifies tests and requirements recommended for the specific mounting location on/in the road vehicle.	TVS Diode	Global
ISO 10605:2008	Road vehicles – test methods for electrical disturbances from electrostatic discharge	This standard specifies the electrostatic discharge (ESD) test methods necessary to evaluate electronic modules intended for vehicle use. It includes these sources of ESD: in assembly, by service staff, by vehicle occupants.	Diode Array PulseGuard (AXGD) Multilayer Varistor	Global

More information can be found at [Littelfuse.com](https://www.littelfuse.com)

Explore the world of Littelfuse with the electronic ecatalogs (ecatalogs.littelfuse.com)

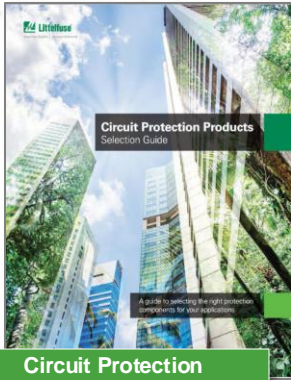

Circuit Protection Selection Guide

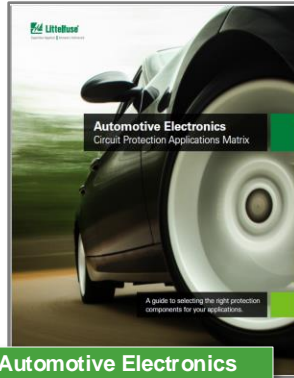

Automotive Electronics Application Guide



ESD Suppression Selection Guide



ESD Protection Selection Guide

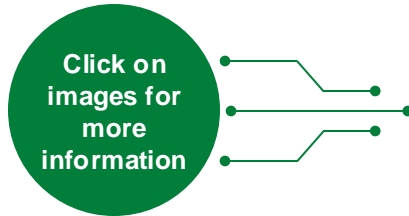

TVS Diode Catalog and Design Guide

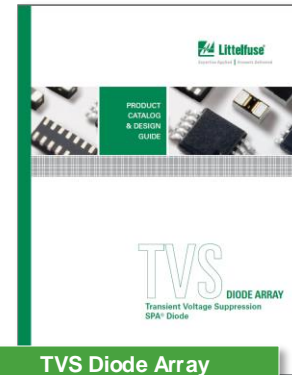

TVS Diode Array Selection Guide

Local resources supporting our global customers

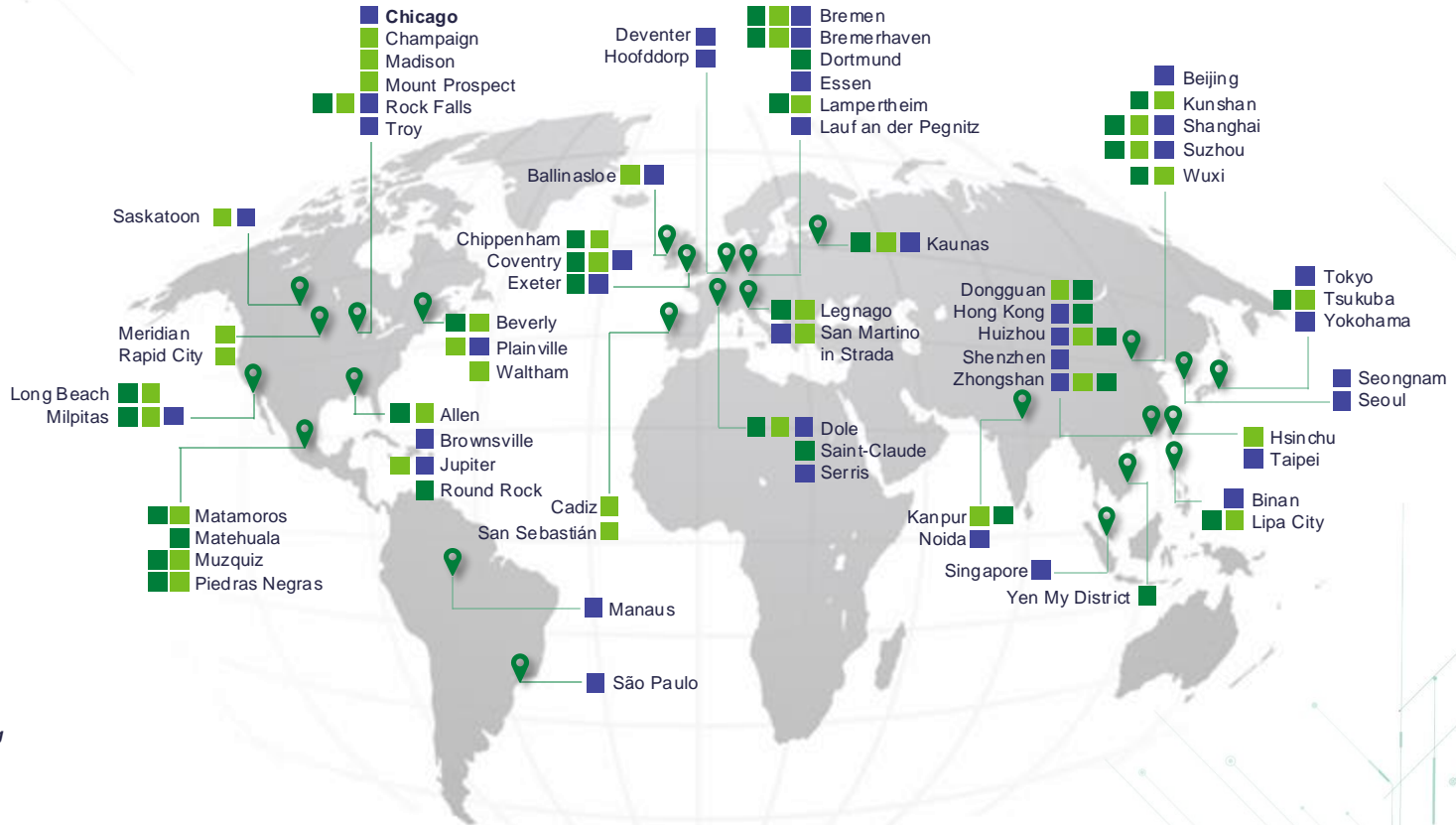

Legend

- Sales
- R&D
- Manufacturing

Partner for tomorrow's electronic systems

Broad Product Portfolio

An industrial technology manufacturing company empowering a sustainable, connected, and safer world

Testing Capabilities

We help customers get products to market faster, we offer certification testing to global regulatory standards

Application Expertise

Our engineers partner directly with customers to help speed up product design and meet their unique needs

Compliance & Regulatory

We help customers in the design process to account for requirements set by global regulatory authorities

Global Customer Service

Our global customer service team is with you to anticipate your needs and ensure a seamless experience

Global Manufacturing

High-volume manufacturing that is committed to the highest quality standards



This document is provided by Littelfuse, Inc. ("Littelfuse") for informational and guideline purposes only. Littelfuse assumes no liability for errors or omissions in this document or for any of the information contained herein. Information is provided on an "as is" and "with all faults" basis for evaluation purposes only. Applications described are for illustrative purposes only, and Littelfuse makes no representation that such applications will be suitable for the customer's specific use without further testing or modification. Littelfuse disclaims all warranties, whether express, implied, or statutory, including but not limited to the implied warranties of merchantability and fitness for a particular purpose and non-infringement. It is the customer's sole responsibility to determine suitability for a particular system or use based on their own performance criteria, conditions, specific application, compatibility with other components, and environmental conditions. Customers must independently provide appropriate design and operating safeguards to minimize any risks associated with their applications and products. Read complete Disclaimer Notice at: www.littelfuse.com/disclaimer-electronics.



Expertise Applied | Answers Delivered

Littelfuse.com